

TABLE OF CONTENTS

Para.	Title	Page	Para.	Title	Page
1.0	GENERAL DESCRIPTION	1-1	4.0	SERVICE	4-1
1.1	Purpose of Manual	1-1	4.1	General	4-1
1.2	Description of Centrifuge	1-1	4.2	Operating Theory	4-1
1.3	Specifications	1-1	4.2.1	Power Circuit	4-3
1.4	Warranty	1-3	4.2.2	Motor Circuit	4-4
1.5	Ordering Information and Factory Returns	1-3	4.2.3	Motor Control Board	4-6
1.6	Registration of Instrument	1-3	4.2.4	Tach/Time Board	4-6
			4.2.5	Controls and Circuit Devices	4-6
2.0	INSTALLATION	2-1	4.2.5.1	Start Switch S1	4-6
2.1	General	2-1	4.2.5.2	Brake Switch S2	4-10
2.2	Receiving Inspection	2-1	4.2.5.3	TIME Switch S3	4-11
2.3	Unpacking and Inspection Procedure	2-1	4.2.5.4	STOP Switch S4	4-11
2.4	Setup and Installation	2-1	4.2.5.5	TIME Set Switch S5	4-12
2.4.1	Preliminary Checkout	2-1	4.2.5.6	SPEED Select Switch S6	4-12
2.4.2	Installation Checkout	2-4	4.2.5.7	Imbalance Switch S7	4-12
			4.2.5.8	Cover Switch S8	4-12
3.0	OPERATION	3-1	4.2.5.9	Fan Relay K1	4-13
3.1	General	3-1	4.2.5.10	Hall Effect Sensor	4-13
3.2	Description of Operation	3-1	4.3	Troubleshooting	4-15
3.2.1	Control Panel	3-1			
3.2.2	Data Plate/Power Cord/Fuse	3-3		ILLUSTRATIONS	
3.3	Operational Precautions	3-3	Figure	Title	Page
3.4	Operating Procedure	3-4	1-1	Outline Dimensions	1-4
3.4.1	Precooling	3-4	2-1	Unpacking	2-2
3.4.2	Opening the Cover	3-6	2-2	Centra-8R Centrifuge	2-5
3.4.3	Installing the Rotor	3-7	2-3	Air Circulation	2-5
3.4.4	Loading the Rotor	3-7	3-1	Control Panel	3-0
3.4.5	Closing The Cover	3-8	3-2	Installing Rotor	3-7
3.4.6	Programming the Run Cycle	3-8	3-3	Cover Interlock Bypass	3-13
3.4.7	Starting the Run Cycle	3-8	3-4	Brush Replacement	3-14
3.4.8	Stopping the Run Cycle	3-8	3-5	Main Fuse Replacement	3-15
3.4.9	Changing Modes During Operation	3-8	4-1	System Functional Diagram	4-1
3.4.10	Determination of RCF	3-9	4-2	System Schematic Diagram	4-2
3.4.11	Removing the Rotor	3-9	4-3	Power Circuit	4-3
3.5	Care and Cleaning of IEC Rotors and Structural Accessories	3-9	4-4	Motor Circuit	4-4
3.5.1	Corrosion	3-9	4-5	Motor and Motor Fan Functional Diagram	4-5
3.5.2	Inspection	3-9	4-6	Motor Control Board Circuit	4-6
3.5.3	Prevention	3-9	4-7	Tach/Time Circuit	4-7
3.5.4	Drying	3-9	4-8	System Wiring Diagram	4-8
3.5.5	Corrosion Removal	3-9	4-9	Start Switch S1 Wiring Diagram	4-10
3.6	Cleaning the Centrifuge	3-10	4-10	Brake Switch S2 Wiring Diagram	4-10
3.7	Cover Interlock Mechanical Safety Bypass	3-13	4-11	Time Switch S3 Wiring Diagram	4-11
3.8	Motor Brush Removal/ Replacement	3-13	4-12	STOP Switch S4 Wiring Diagram	4-11
3.9	Commutator Inspection	3-14	4-13	Imbalance Switch S7 Wiring Diagram	4-12
3.10	Fuse Replacement	3-15	4-14	Cover Switch S8 Wiring Diagram	4-13
			4-15	Fan Relay K1 Wiring Diagram	4-13
			4-16	Hall Effect Sensor Wiring Diagram	4-13
			4-17	Refrigeration System	4-14
			4-18	Compressor Circuit	4-15
			4-19	Display P.C. Board Schematic	4-18

TABLE OF CONTENTS (Continued)

TABLES

Table	Title	Page
1-1	Specifications	1-2
3-1	Nomograph	3-7
4-1	Troubleshooting Chart	4-16

1.0 GENERAL DESCRIPTION

1.1 Purpose of Manual

This manual provides installing, operating and servicing instructions for the Model Centra®-8R Centrifuge manufactured by the International Equipment Company (IEC), a Division of Damon Corporation.

1.2 Description of Centrifuge

The Centra-8R is a refrigerated, general purpose, digital benchtop centrifuge designed for use in the medical, industrial, and scientific laboratory to perform separations by centrifugal force. The centrifuge will accommodate tubes, bottles, and blood bags. It is registered as a device in accordance with FDA Regulations governing distribution and use of such products.

The Centra-8R is designed for 120 VAC, 50/60 Hz (Catalog No. 2478), and 100, 120, 200, 220 or 240 VAC, 50/60 Hz (Catalog No. 2479) operation.

A cabinet supports the centrifuge chamber which is comprised of a corrosion-resistant, stainless-steel guard bowl. The evaporator portion of the refrigeration system is attached to the outside surface of the guard bowl and is encased in a plastic foam insulator. Two protective steel burst plates are mounted to the cabinet in front of this insulator.

The temperature within the centrifuge chamber is controlled and indicated at the control panel. The chamber is cooled from ambient to any set point within the 0° to 39°C temperature range and is maintained by an on-off cycling of the compressor.

A counter-balanced cover assembly forms the top section of the chamber. The latch control knob on the front panel and latch assembly in the cabinet housing provide an interlock. This interlock prevents opening the cover of the centrifuge when the rotor is turning or, if the cover is not completely closed and latched, prevents activation of the centrifuge.

A rotor drive assembly is mounted to the cabinet base through the center of the guard bowl. The drive assembly employs a permanent magnet motor. The motor has permanently sealed self-lubricating ball bear-

ings. Motor brushes are replaceable from within the chamber.

The rear section of the cabinet houses the main refrigeration components which includes: a compressor, a condenser, a fan and associated tubing. Cooling air is drawn in from the bottom, and the right and left sides and exhausted through the rear and sides of the refrigeration compartment.

A dynamic electric brake provides control of deceleration of the drive assembly.

A removable control panel is located at the lower front of the cabinet. The controls on this panel are used to apply electrical power and to set the chamber temperature, speed timing, braking, and the run-cycle starting and stopping modes of the centrifuge.

An out-of-balance switch actuates when the rotor imbalance is excessive. When this switch is actuated, IMBALANCE is displayed on the front panel and the rotor will decelerate to a stop. The imbalance switch, a fan relay, a latch switch, a latch solenoid and a motor control and logic printed circuit (PC) board are located within the cabinet housing.

The remaining major electrical and electronic components are located on the rear of the control panel along with the tachometer timer display, the temperature display, and the five volt power supply PC boards. These are accessible after the control panel assembly is removed.

Most of these parts have connectors to facilitate servicing, or replacement.

A fuse and a power cord are also part of the cabinet assembly.

The inlet vents, coupled with a blower fan assembly within the cabinet, provide drive assembly motor cooling.

Five suction cup feet, mounted on the base of the unit, increase stability.

1.3 Specifications

Table 1-1 provides a quick-reference listing of the major specifications.

TABLE I-1 SPECIFICATIONS

*Maximum Speed of Rotation	
Angle (811a) Rotor, W/356 Shields	5800 RPM
Horizontal (921) Rotor W/366 Trunnion Rings and 369 Carriers	4800 RPM
*Maximum Relative Centrifugal Force (RCF)	
Angle (845a) Rotor, W/2944 Bottles	5060 x g
Horizontal (921) Rotor, W/310 Trunnion Rings and 303 Shields	4160 x g
*Maximum Volume	
Angle (845a) Rotor, W/2944 Bottles	1920 ml (8 x 240 ml)
Horizontal (216) Rotor, W/2272 Bottles	3000 ml (4 x 750 ml)
*Maximum Tube Capacity	
Angle (822a) Rotor, W/320 Shields and 7249 Adapters	84 Tubes (1 ml)
Horizontal (216) Rotor, W/5737 Adapters	148 Tubes (3-5 ml)
Speed Control	
Range	500 - 5900 RPM
Increments	100 RPM
Accuracy	± 10 RPM
Speed Display	
Range	1 - 5900 RPM
Increments	1 RPM
Temperature Control	
Set Range	0°C to + 39°C
Sample Temperature Stability	± 1°C
Increments	1°C
Temperature Display	
Range	0°C to + 39°C
Increments	1°C
Accuracy	± 1°C
Timer	
Range	1 - 59 Min., or Hold Position
Increments	1 Min.
Type	Quartz Crystal Controlled
Braking System	Dynamic Electric
Drive Assembly Motor	0.6 HP @ 5000 RPM
Compressor Motor	1/3 HP
Power Requirements:	Catalog No. 2478 Catalog No. 2479
	120 VAC ± 10%, 50/60 Hz, 15 Amps. 100,120 ± 10%, 50/60 Hz, 15 Amps. 200,220,240 ± 10%, 50/60 Hz, 10 Amps.
Fuse	15 Amps. (10 Amps. for 200, 220 or 240 VAC machines)
Power Consumption	1500 Watts, Max., Operating
Total Heat Produced	3000 BTU/Hr., Operating
Refrigerant	R-12 (391 gm.) (13.8 oz.)
Operational Head Pressure	130 - 140 psig @ 0°C
Operational Suction Pressure	12 - 13 psig @ 0°C
Net Weight:	Catalog No. 2478 Catalog No. 2479
	101.15 kg (223 lbs.) 112.95 kg (249 lbs.)
Shipping Weight:	Catalog No. 2478 Catalog No. 2479
	108.41 kg (239 lbs.) 120.20 kg (265 lbs.)
Centrifuge Dimensions:	
Height (with cover open)	915 mm (36.02 in.)
Height (with cover closed)	438 mm (17.25 in.)
Width	584 mm (23.00 in.)
Depth	762 mm (30.00 in.)
Inside Diameter of Guard Bowl	438 mm (17.25 in.)
Packing Case Dimensions:	
Height	705 mm (27.75 in.)
Width	711 mm (28.00 in.)
Depth	914 mm (36.00 in.)
Volume	0.46 m ³ (16.19 ft. ³)

The Centra-8R is shipped with a rotor locking nut wrench, Part No. 1787, and Instruction Manual, IM-221.

*Refer to Table 3-2 for complete accessories combinations, relative centrifugal forces (RCF), speed ranges, and related data.

1.4 Warranty

International Equipment Company (IEC) warrants that it will repair or replace, free of charge to an Authorized Dealer of IEC any instrument which fails within one (1) year after delivery to the original customer because of defective material or workmanship, provided it does not fail under the exceptions and conditions specified in the warranty given with the instrument. Such exceptions and conditions include, but are not limited to, failure of parts due to natural wear, accident, neglect or operation in a manner not prescribed in the operating instructions supplied with the instrument. The foregoing expresses IEC's sole warranty with respect to the instrument. THIS WARRANTY IS MADE IN LIEU OF ANY AND ALL OTHER WARRANTIES AND ALL IMPLIED WARRANTIES OF MERCHANTABILITY AND FITNESS FOR A PARTICULAR PURPOSE ARE HEREBY DISCLAIMED AND EXCLUDED. IEC and its Authorized Dealers will not be liable for consequential damages, loss or expense arising from the improper use of the instrument. IEC will not honor any other warranty given by the Authorized Dealer which is different from the warranty given by IEC. This warranty is not assignable and is operative only in favor of the original customer to whom this warranty is delivered.

DEALER OBLIGATION UNDER WARRANTY

Customer requesting service for an instrument during the period covered by warranty should receive a response, within a 48-hour period, from the Authorized Dealer who sold the instrument. If this obligation is not met and the customer so advises IEC, such Authorized Dealer will be notified of, and responsible for, the action taken, and expense incurred, by IEC in satisfying the customer.

DISCLAIMERS AND EXCLUSIONS

The Installation, Operation and Service Manual supplied with this instrument includes a service trouble-shooting chart. However, you are under no obligation to locate or remedy any service problem. You hereby release and forever discharge IEC, its successors, assigns, subsidiaries, affiliates, officers, agents, and employees from any and all claims, demands and liabilities in law or in equity, of any nature, based upon, arising out of, or resulting from locating, remedying or attempting to locate or remedy any service problem. Should service be required, contact the dealer from whom you purchased this instrument to obtain service by factory-trained personnel.

The information included in this Installation, Operation and Service Manual is believed adequate for the operation and intended use of this instrument. If the instrument is to be used for any purpose exceeding or deviating from the capabilities specified herein, then written confirmation or acceptability for such purpose should be obtained from IEC. Failure to do so will affect the warranty, and IEC will not guarantee any results nor assume any obligation or liability arising from such confirmed action.

1.5 Ordering Information and Factory Returns

To obtain service and/or replacement parts under warranty, you should contact the authorized IEC dealer from whom you purchased your instrument, or write directly to IEC, 300 Second Avenue, Needham Heights, Massachusetts 02194, Attention: Service Manager. Your correspondence must include the model and serial number of your instrument, the date of its delivery, and the name of the dealer from whom you purchased it. IEC will not accept goods returned without proper authorization. A "Returned Goods Authorization" (RGA) must be obtained through a dealer and accompany the prepaid return shipment.

To obtain service and/or replacement parts not under warranty, or to order additional accessories, you may contact any authorized IEC dealer.

NOTE: In the event you wish to return the machine or any part, you must comply with the following.

1. If the instrument or any part has been exposed to, or used to process, dangerous pathogenic or radioactive material, you are required to decontaminate the instrument or part being returned to insure there is no radioactivity or harmful bacteria present and to advise us accordingly.
2. Decontaminate the instrument or any part that may have accumulated blood or any other chemical deposits by using standard laboratory procedures. Should this instrument or any part be received in a condition we consider to be a potential biological hazard to our personnel, it will be returned to you unrepaired, at your expense.

1.6 Registration of Instrument

For registration purposes please fill out the Warranty Registration/Installation Report form supplied with the instrument. Return the completed form to IEC.

2.0 INSTALLATION

2.1 General

The Centrifuge is shipped in a special carton designed to protect it against normal shipping hazards. Installation of the centrifuge includes an initial inspection of the carton before acceptance from the shipper, moving the carton to the operating location or incoming inspection area, unpacking, preliminary check-out, and installation for use.

2.2 Receiving Inspection

Before signing the delivery receipt and accepting the shipment, inspect the shipping carton for any signs of mishandling, such as broken or dented sides. Damage to the carton must be noted and a written statement made on the delivery receipt before signing, describing the nature of the damage. A normal or undamaged carton does not necessarily ensure that the contents have not been damaged during shipping. If mishandling, or damage, is suspected, contact the office of the carrier so that a representative may witness the unpacking. The centrifuge and other contents of the carton should be carefully examined as the unpacking proceeds. Any damage discovered, which can be attributed to mishandling or shipping damage, should be documented and a signed inspection report should be furnished to the shipping company. IEC is not responsible for damage incurred in transit.

2.3 Unpacking and Inspection Procedure

These instructions may be found on the shipping carton also.

CAUTION: THE UNIT WEIGHS OVER 200 LBS. (90.72 kg). UNPACKING AND INSTALLATION REQUIRES THE SERVICE OF TWO PEOPLE AND A HAND TRUCK OR A ROLLER LIFT.

Refer to Figure 2-1

1. Move the carton to the intended operating location, or a convenient area, for inspection. Keep all shipping documents.

2. Open the top of the carton and remove all accessible packing material and shipping supports. Inspect the centrifuge for obvious damage; if none, proceed.

3. With a partner, remove the centrifuge from the carton by reaching down inside the carton, grasping and lifting the centrifuge out of the carton. Save the carton and shipping material for possible re-use.

2.4 Setup and Installation

CAUTION: THESE PROCEDURES ARE TO BE COMPLETED BY QUALIFIED PERSONNEL ONLY. DO NOT ATTEMPT TO OPERATE THIS CENTRIFUGE BEFORE THOROUGHLY READING THIS MANUAL.

Refer to Figure 2-2

2.4.1 Preliminary Checkout

This procedure is used to ensure that the electrical line-voltage outlet is compatible with the electrical requirements of the centrifuge. Ideally the centrifuge should have its own separate branch circuit so that line load variations will be minimized. The wall outlet must be an AC, three-wire, grounded, single-phase circuit located within six feet of the centrifuge. The outlet should be easily accessible to allow the power line cord to be quickly disconnected.

Check the electrical requirements (voltage and frequency) shown on the dataplate, located on the left side of the centrifuge. Use an AC voltmeter to measure the voltage at the power outlet that the centrifuge power line cord will be plugged into. Check that the line voltage at the outlet is the same as the voltage shown on the dataplate.

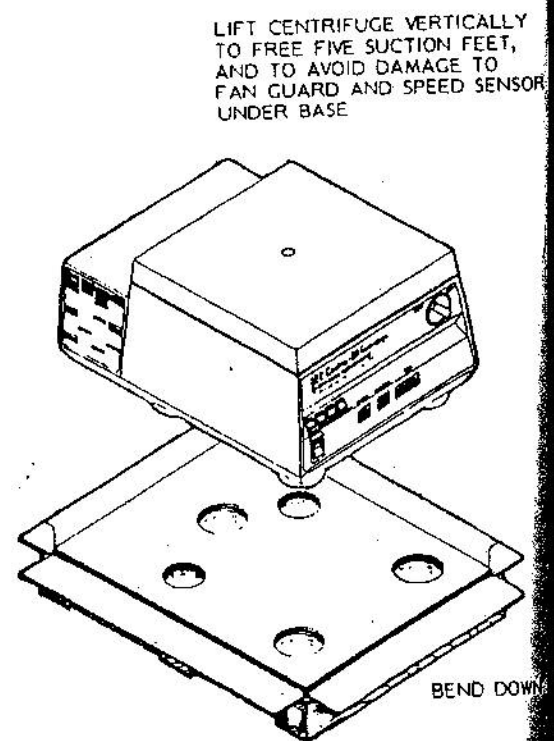
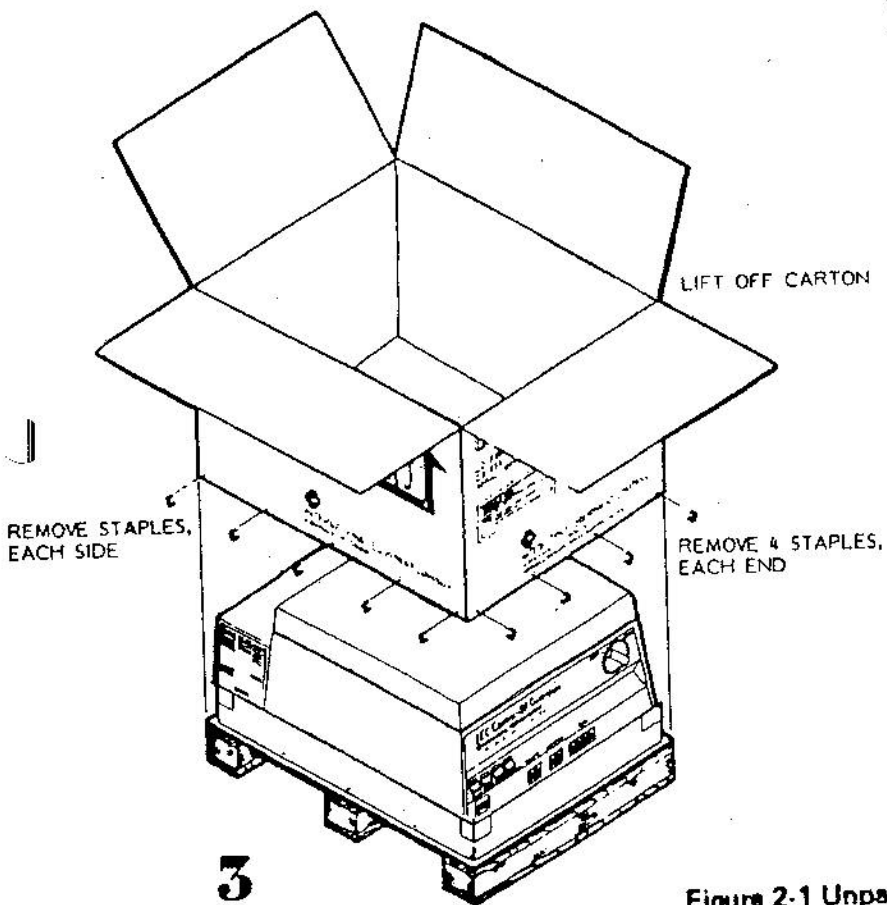
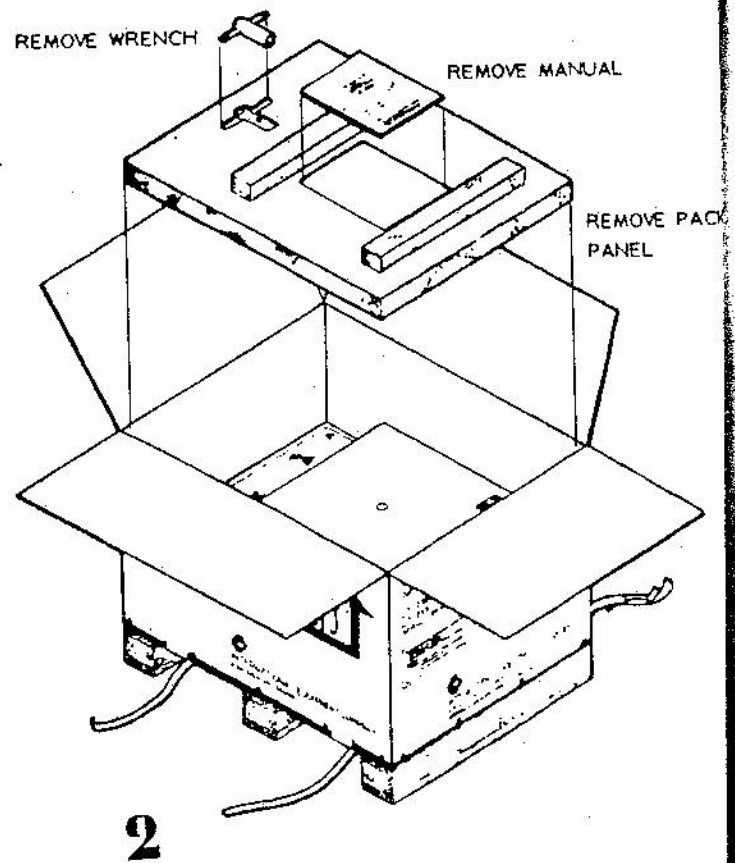
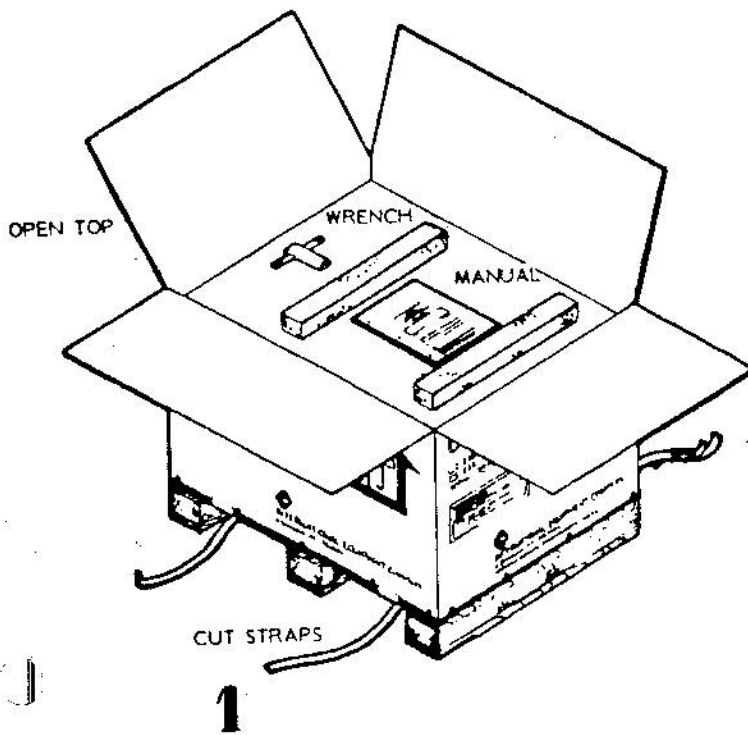

Figure 2-1 Unpacking

Check with your power company as to line frequency also shown on the dataplate.

Proceed as follows:

1. Catalog No. 2478: 120 VAC, 50/60Hz Instrument. Line voltage must be between 108 VAC and 132 VAC. If outside these limits, an external voltage step-up or stepdown transformer will be required.

2. Catalog No. 2479: 100, 120, 200, 220 or 240 VAC, 50/60Hz Instrument. Line voltage must be within the limits shown below:

Line Voltage (VAC)	Limits (VAC)
100	90 - 110
120	108 - 132
200	180 - 220
220	198 - 242
240	216 - 264

If outside these limits, an external voltage step-up or step-down transformer will be required. Line frequency must not be below 48 Hz.

CAUTION: OPERATION BELOW 48 Hz COULD AFFECT SPEED SETTINGS AND RESULTS, AND WILL VOID THE WARRANTY.

Note that fluctuations in line voltage as well as frequency will alter maximum rotor speeds with respect to the values listed in the Speed and Force Table of this Manual. If the line voltage and frequency are suitable for your centrifuge, you are ready to proceed to the installation checkout.

2.4.1.1 Electrical Connections

Catalog No. 2478 instruments do not require any electrical connections other than to plug the unit into the correct power outlet.

However, Catalog No. 2479 instruments are shipped from the factory for 240 VAC, 50/60 Hz operation with a 10 Amp main power line fuse.

Therefore, for operation with either 100, 120, 200 or 220 VAC, 50/60 Hz operation, a single brown wire, #128, must be moved from its 240V tap to the appropriate tap.

Also, in 100V and 120V applications, a 15 Amp fuse and its label must replace the 10 Amp main power line fuse and its label. The 15 Amp fuse and label are part of the spare parts kit which is attached within the base assembly of the unit.

If the instrument is a Catalog No. 2479, make the following changes:

- Remove the refrigeration compartment cover.
- Locate the auto transformer T1, directly behind the drive motor and shown in Figure 2-2.
- Locate the terminal strip on the top of T1 shown in Figure 2-2.
- The leads from T1 go directly to the top row of terminal screws on the strip. DO NOT ATTEMPT TO CHANGE THESE LEADS. The change is to be made on the bottom row of screws.
- Move the brown wire, #128, from the 240 terminal (the one closest to the rear of the unit) to the appropriate terminal. NOTE: If the input voltage is 120V there will be another wire on the terminal. Be sure to note its number and to re-attach it together with wire #128.
- Replace the 10 Amp line fuse and label with the 15 Amp fuse and label.
- Replace the refrigeration compartment cover.

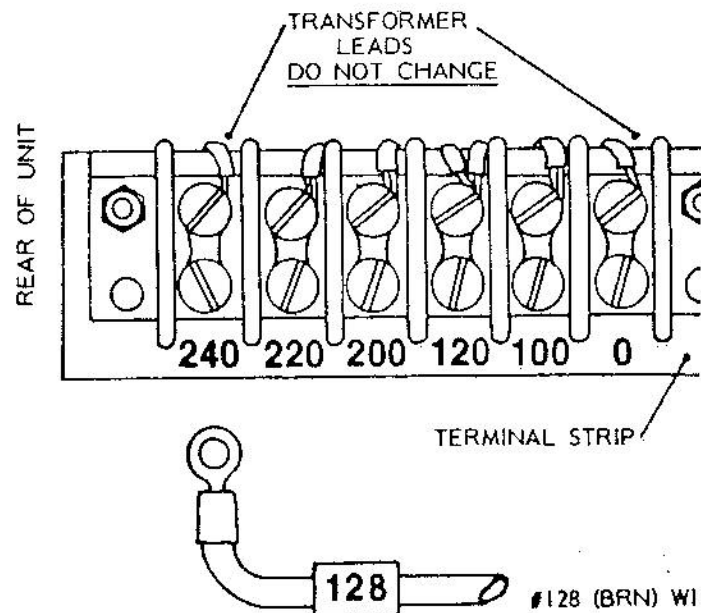

Auto Transformer Connections
International (2479)

2.4.2 Installation Checkout

Perform the installation checkout procedures as listed below. Refer to Section 3.0 OPERATION, and Figure 3-1 as needed. With no, or with improper, operation at any of these checkout steps, consult your authorized IEC dealer, or see the troubleshooting chart in this manual. See the Warranty in Section 1.

1. Push the Power switch to the OFF position. (Indicator lamp goes off.)

2. Set the RPM control and the Time control to zero and the Brake control to the OFF position.

3. Place the centrifuge on a firm flat, clean bench or table which is substantial in construction, and is permanently affixed to the wall and/or floor. Leave six inches of free space around the unit.

NOTE: To assist in moving the centrifuge into its final location on the table, or bench, place paper, or cardboard, under each suction cup foot. Slide the centrifuge into position. Lift each side, in turn, to remove the paper or cardboard.

CAUTION: ENSURE THAT THE VENTS ARE NOT BLOCKED, AS THIS WILL IMPAIR VENTILATION OF THE CENTRIFUGE.

4. Set the TEMP °C to +10°C. Check that all other controls are in the zero or OFF position. Plug the power cord into the correctly-rated power outlet. Set the Power switch to ON. The Power and the Stop indicators will light, and the refrigeration system will operate.

5. Open the cover by turning the latch knob clockwise (CW) one-quarter turn.

6. Remove the rotor by turning the shaft hex nut CCW using the rotor wrench, IEC Part No. 1787, supplied with the centrifuge.

7. Install any appropriate IEC rotor with a full complement of properly-balanced accessories.

8. Use the IEC Part No. 1787 wrench to TIGHTEN THE HEX NUT. Close and latch the cover by turning the latch knob one-quarter turn CCW.

9. Set the Speed control at the maximum listed speed for the rotor used. Refer to the Speed and Force and Accessory Table, Table 3-2.

10. Set the Timer to the Hold position.

11. Set the rotor Brake control to the ON position.

12. Push the Start button. The Stop indicator will go "off" and the Start light will go "on" as the rotor accelerates. Try to open the cover at this time by turning the latch knob CW to check the safety cover interlock. The cover should not open. Set the Timer to the Time position. Set the Timer to 5. Push the Start button. Observe the Speed indicator for acceleration. Use a stopwatch or a clock to check the accuracy of several different Timer settings.

13. Allow the Timer to stop the run.

14. When the Stop indicator lights, set the Timer to Hold. Push the Start button.

15. Allow the motor to reach the same preset speed and to stabilize. Set the Brake control to OFF, push the Stop button and record the coast period. The Stop indicator will light when the motor stops. Push the Start button.

16. Allow the motor to reach the same preset speed and to stabilize again. Set the brake control to ON. Push the Stop button and record the deceleration period. This should be approximately 1/3 the coast period.

17. Set the RPM control to 500 RPM; set the Timer to HOLD. Push the START button. Allow the centrifuge to cool to the +10°C set temperature. When the temperature readout is approximately +8°C, the refrigeration system should stop operating. Set the RPM control to 3000 RPM; the refrigeration system should restart at a temperature reading of approximately +12°C.

18. Set the TEMP °C control to 0°C and the RPM control to 1000 RPM. After approximately 15 minutes the temperature should read approximately the same as the set temperature and the refrigeration system should begin to cycle on and off. Set the RPM control to its maximum setting. The refrigeration system should continue to cycle.

If all of the preceding checks appear normal, then the checkout procedure is complete.

NOTE: If it is desired to relocate the centrifuge: ALWAYS remove the rotor before attempting to move the centrifuge; otherwise the motor drive shaft may be bent or damaged.

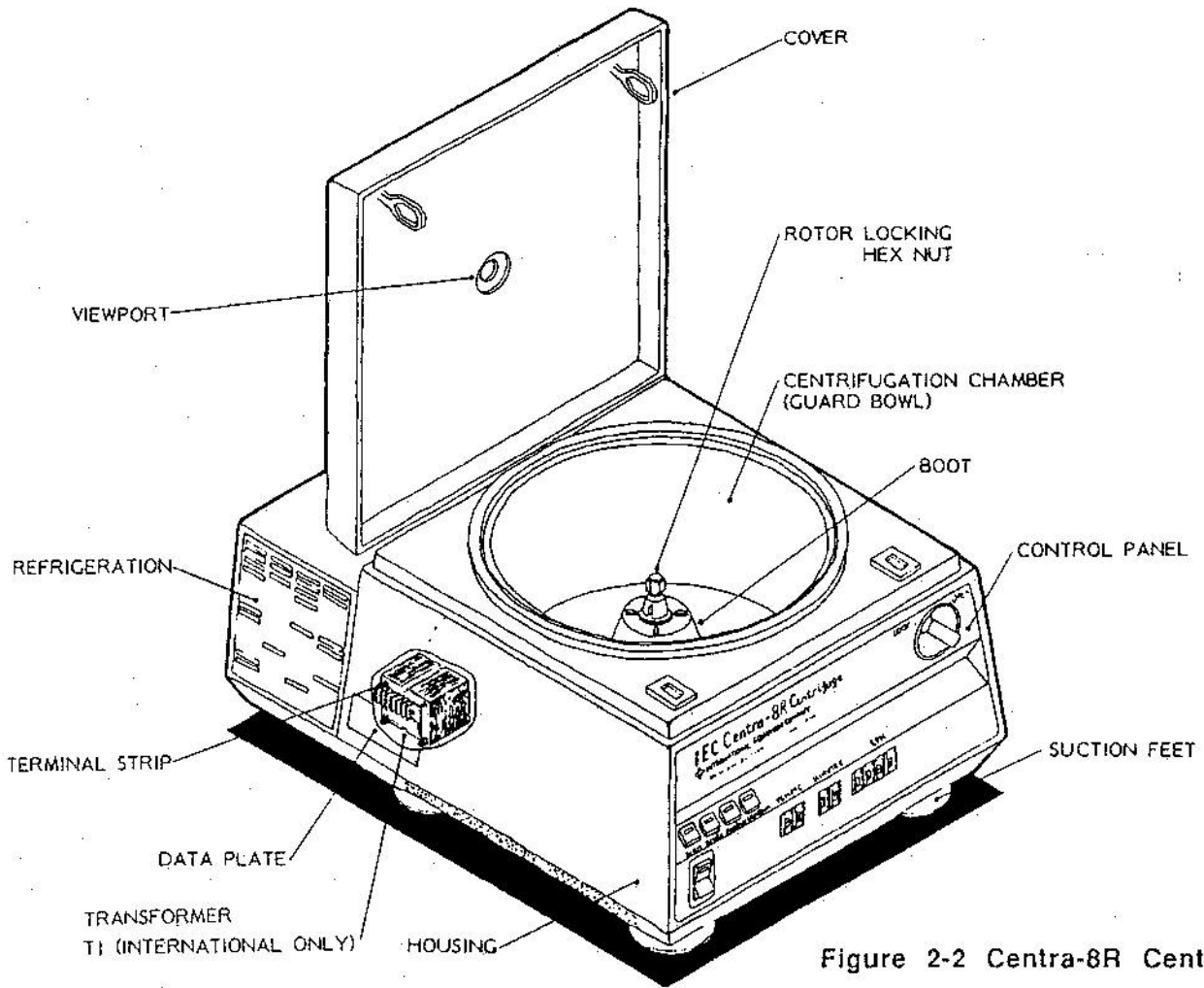

Figure 2-2 Centra-8R Centrifuge

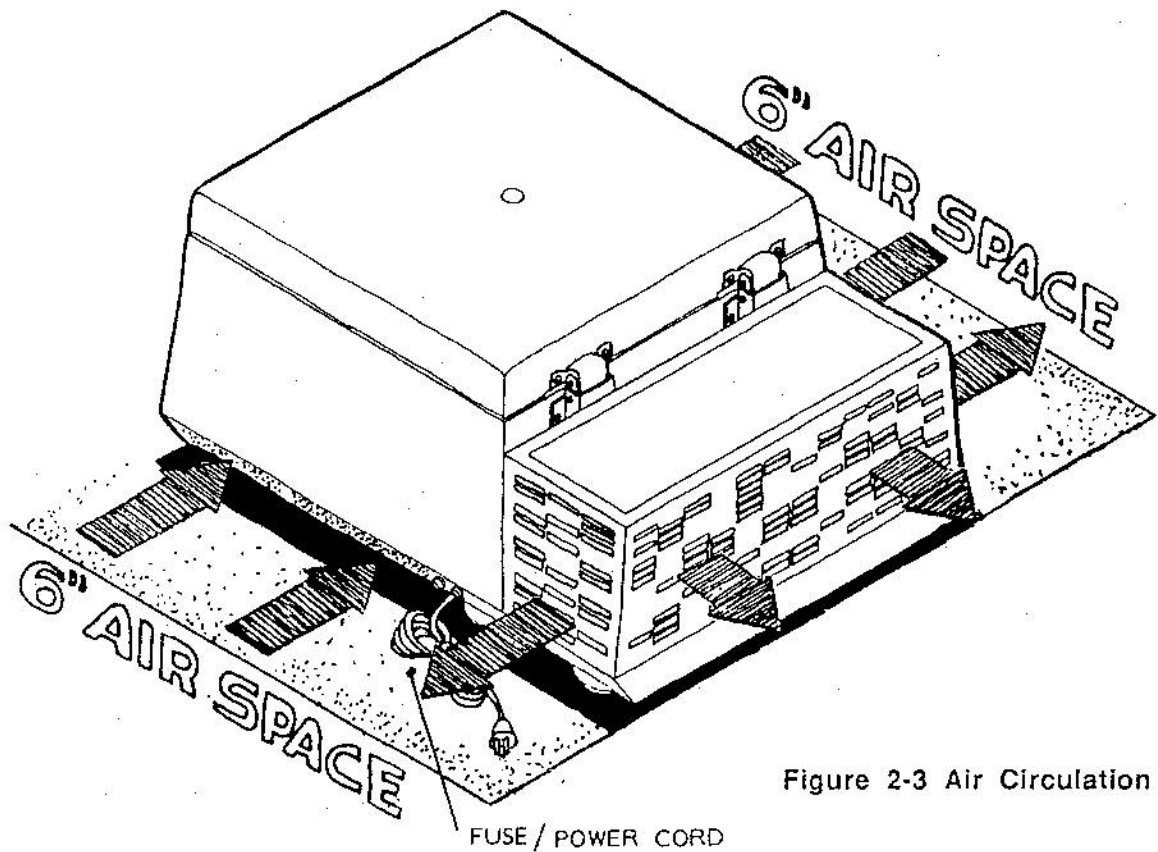
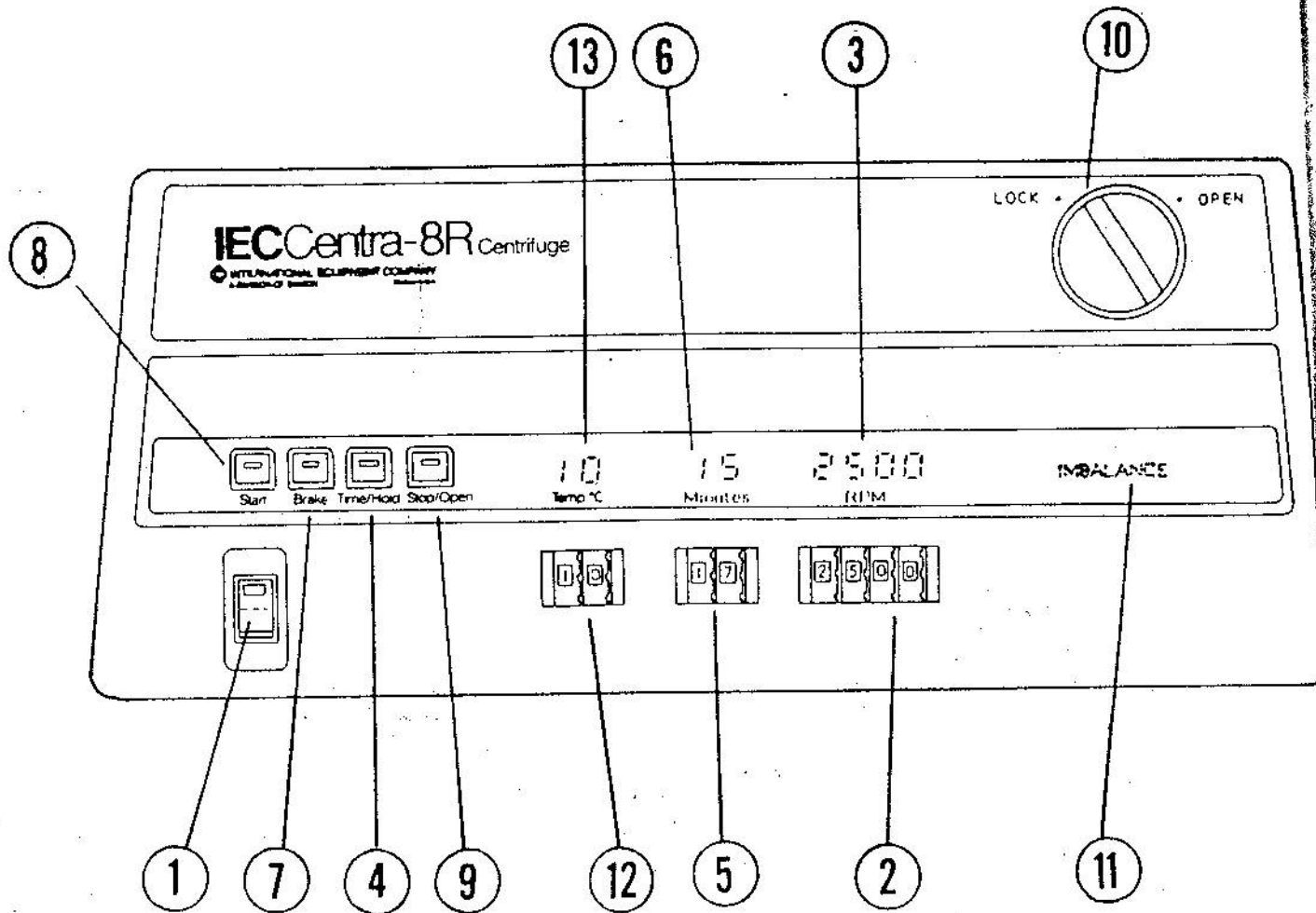

Figure 2-3 Air Circulation



- | | |
|--|---|
| 1. Power Switch/Indicator | 9. Stop-Run/Open-Cover Switch Indicator |
| 2. Speed (RPM) Select Switch | 10. Unlatch (OPEN)/Latch (LOCK) Knob |
| 3. Speed (RPM) Indicator | 11. Imbalance Indicator |
| 4. Time/Hold Mode Switch/Indicator | 12. Temperature (TEMP°C) Switch |
| 5. Timer (Minutes) Setting Switch | 13. Temperature (TEMP°C) Indicator |
| 6. Set and Countdown Time Indicator | |
| 7. Brake Switch/Indicator | |
| 8. Start-Run, Start/Reset Countdown Timer Switch/Indicator | |

Figure 3-1 Control Panel

3.0 OPERATION

3.1 General

This section contains instructions for the operation of the centrifuge and is intended to acquaint the user with the various controls, indicators, and operating characteristics of the instrument. Table 3-1 is a nomograph for computing relative centrifugal force (RCF).

3.2 Description of Operation

Centrifuge operation normally involves: Applying power, opening the cover, installing a rotor, installing a balanced load in the rotor, selecting the desired temperature speed and timing modes, closing the cover, starting the run cycle, terminating the run cycle (unless the timing function has been selected, in which case the run automatically terminates at the end of the timed duration), opening the cover, and removing the rotor. The following paragraph describes the controls involved in operation.

3.2.1 Control Panel

All of the controls and indicators necessary to operate and monitor the centrifuge are located on the control panel at the lower front of the instrument, and are shown in Figure 3-1.

1. Power Switch/Indicator

This two-position, rocker switch/indicator is used to control power to the instrument. The top of the rocker section of the switch illuminates when in the ON position. Set the switch to OFF when the instrument is not in use.

2. Speed (RPM) Select Switch/Indicator

The first two thumbwheels of this four-thumbwheel switch are used to select any rotor speed from 500 to maximum RPM in 100 RPM increments. After setting the desired speed, use the Speed indicator for ascertaining the actual speed. Speed may be reset any time before or during a run cycle.

3. Speed (RPM)/Indicator

This initially blank, red indicator shows the actual rotor speed.

4. Time/Hold Mode Switch/Indicator

This alternate-action, pushbutton switch is used to select the hold (untimed) mode for runs exceeding 59 minutes, or when timing is not desired; or the timed (up to 59 minutes) mode of operation. When the button is depressed (Hold position) the yellow-indicator lights. If timing is desired, depress the button again. The yellow indicator does not light in the timed position.

5. Timer (Minutes) Setting Switch

This dual thumbwheel switch is used with the Time/Hold mode switch to select timed run of up to 59 minutes.

6. Set and Countdown Time/Indicator

This initially blank, red indicator initially shows the set timed period then it shows the time remaining.

7. Brake Switch/Indicator

This alternate-action pushbutton switch is used to select the rotor-braking mode when desired. When the button is depressed the yellow indicator lights and the electric dynamic brake is energized. The rotor will stop in approximately one-third of the coasting (no brake) time.

When set to the OFF (non-depressed) position there is no braking force applied to the drive motor and the rotor will coast freely to rest.

Coasting and braking time depends on the rotor, load and speed.

8. Start Run, Start Reset Countdown Timer Switch/Indicator

This momentary-contact pushbutton switch is used to begin the run cycle after speed, time and braking modes have been selected and the cover is closed and latch

The centrifuge cannot be started until the cover is securely closed and latched. The run will continue automatically through the time and braking modes.

NOTE: If power to the instrument is interrupted, the run will automatically be ended to prevent inadvertent start-up when power is restored. The Start button must be pushed again to resume the run after the rotor stops completely.

The green indicator lights when the run begins. This switch also starts or updates (shows original time setting) and starts the timer countdown in the timed mode.

9. Stop-Run/Open Cover Switch Indicator

This momentary-contact pushbutton switch is used to end the run cycle when in the untimed (Hold) mode. It may be used at any time to de-energize the drive motor. When this button is pressed, the rotor decelerates (coasts or brakes) to a stop. This switch is also used to open the cover when the run cycle is over (when the red indicator is lit). There is a five-second interval allowed when the button is pressed to open the cover. For an additional five-seconds press the button again.

The red indicator on the switch button lights only to indicate that the rotor has stopped. To open the cover, press the button. You have five seconds to open the cover; otherwise, you must press the button again.

10. Imbalance/Indicator

This normally blank red indicator lights only when there is a rotor load imbalance. When this happens the run cycle is terminated and the rotor will coast or brake (if on) to a stop.

11. Unlatch (OPEN)/Latch (LOCK) Knob

This control is used to open or lock the cover. It can only be used when the Power and Stop/Open indicators are lit. Turn the knob one-quarter turn counter-clockwise (CCW) to open, or clockwise (CW) to lock the cover.

12. TEMPerature °C Setting Switch

This dual thumbwheel switch is used to select operational temperatures within the centrifuge chamber from 0°C to 39°C in 1°C increments.

NOTE: The switch can be set from 0°C to +39°C. Settings below 0°C will require slower rotor speeds. Settings above 39°C may have slightly warmer sample temperatures.

All IEC rotor accessories will be accurately temperature-controlled within a 0°C and room temperature range provided that each specific rotor and accessory combination does not exceed the maximum speed listed in the Speed and Force Table (Table 3-2).

The natural circulation of air, due to the rotation of the horizontal and angular rotors, serves to maintain a uniform temperature within the chamber during operation.

However, once the rotor stops air no longer circulates throughout the chamber and therefore the temperature distribution becomes less uniform.

To control material temperature more closely throughout the run, refer to Paragraph 3.4.1.

The air temperature in the chamber will fluctuate $\pm 1^\circ\text{C}$ about the set temperature. The temperature of the sample material will be at the set temperature within $\pm 1^\circ\text{C}$.

Temperature may be increased in any moment during the operation.

The chamber is not designed as a storage refrigerator. DO NOT store food or drink in the chamber as it may become contaminated if the chamber has not been kept biologically clean.

13. TEMPerature 0°C Indicator

This initially blank, red indicator shows the chamber temperature with an accuracy of $\pm 1^\circ\text{C}$.

3.2.2 Dataplate / Power Cord / Fuse

A dataplate which specifies the serial number, power requirements, and other pertinent information is located on the left side of the instrument.

A 3-conductor power line cord at the rear of the instrument is used to connect the instrument to an AC power outlet. Consult the dataplate and Paragraph 2.4.1 for the correct power requirements and connections:

A 15-ampere fuse (10-ampere for 200, 220 or 240 VAC systems) located next to the power cord, provides electrical overload protection for the centrifuge.

3.3 Operational Precautions

1. DO NOT ATTEMPT TO OPERATE THIS CENTRIFUGE BEFORE THOROUGHLY READING THIS MANUAL.

2. Do not operate rotors which do not have a full complement of accessories. Refer to Paragraph 3.4.4.

3. Load and balance all rotors properly. See Paragraph 3.4.4.

CAUTION: This centrifuge is protected from running with excessive imbalance loading only. Imbalanced loads which may allow running can result in poor separation. For proper operation and insurance against abuse, opposite rotor loads must be balanced in accordance with Paragraph 3.4.4.

4. **CAUTION:** NEVER USE MERCURY IN CUPS OR SHIELDS FOR BALANCING PURPOSES. REFER TO PARAGRAPH 3.4.4.

5. Do not use other manufacturer's accessories in IEC centrifuges unless specified in the Speed, RCF, and Accessory Table (Table 3-2). Such misuse of IEC products is potentially dangerous and will void the warranty.

6. Do not adjust any of the potentiometers on the Printed Circuit Boards unless recalibration is necessary.

NOTE: Only qualified service personnel using the calibration procedures and equipment described in this manual are to calibrate this instrument.

7. Do not block the vent openings, otherwise air flow will be hampered resulting in poor cooling and early failure of drive motor and refrigeration components. Allow six inches of free space on both sides and at the rear of the instrument.

8. Replace the rotor hex nut securely even when no rotor is used. This will prevent losing it.

9. Set the POWER Switch to the OFF position when the instrument is not in use.

10. Do not use the centrifugation chamber for storage purposes.

11. Clean the instrument immediately after spillage, or after each eight hour period with mild soap and warm water. **CAUTION: DO NOT USE ACETONE TYPE CLEANERS.**

12. Do not leave cigarettes or other smoking materials on top of the instrument. Lit cigarettes will leave unremovable marks.

13. **WARNING:** ALWAYS UNPLUG THE POWER CORD BEFORE REMOVAL OF THE CONTROL PANEL OR REFRIGERATION COMPARTMENT AS THIS EXPOSES ELECTRICAL SHOCK AREAS WHERE POTENTIALLY LETHAL VOLTAGES ARE PRESENT.

14. NEVER REMOVE THE GROUNDING PRONG FROM THE POWER PLUG, OR USE ANY ADAPTER WHICH DOES NOT COMPLETE THE GROUNDING CIRCUIT.

15. DO NOT USE THE POWER SWITCH TO STOP INDIVIDUAL RUNS EXCEPT IN EMERGENCIES.

16. The chamber is not designed as a storage refrigerator. DO NOT store food or drink in the chamber as it may become contaminated if the chamber has not been kept biologically clean.

17. If power is removed for any reason, wait at least one minute before starting up the refrigeration system again. Also, if the temperature setting is to be changed from a higher to a lower one, turn the TEMP°C control to +30°C setting first, then wait approximately one minute before setting the control to the desired temperature. Otherwise, the head pressure in the refrigeration compressor will not be stabilized and compressor damage may result.

18. After each eight hours of steady use, or as needed, defrost the chamber to remove ice buildup. Otherwise, the rotors may contact ice on the chamber walls.

Use a sponge to remove melted ice water from the chamber.

19. NEVER ATTEMPT TO TOUCH A MOVING ROTOR.

20. Biologically infectious materials should be centrifuged only in IEC sealed dome shields (Cat. No. 324 or 1124). The centrifuge and all components must be contaminated when breakage occurs.

21. This centrifuge is not suitable for use in Class I, Group D hazardous locations (atmospheres, containing gasoline, petroleum, naphtha, benzol, lacquer, solvent vapors or natural gas) and it is unsafe to place volatile combustibles in or near the unit.

22. WARNING - NEVER RE-RUN THE ROTOR ONCE THE IMBALANCE SWITCH HAS BEEN TRIPPED. INSTEAD, PERFORM A THOROUGH EXAMINATION OF THE LOADING SYMMETRY AND BALANCE.

23. WARNING

The refrigerant (R12) used in this centrifuge is a heavier-than-air gas which reduces the oxygen available for breathing. When recharging the refrigeration system avoid prolonged breathing of this vapor.

INTENTIONAL MISUSE BY DELIBERATELY INHALING THE VAPORS OF THE REFRIGERANT CAN BE FATAL.

Provide adequate ventilation for the storage, handling and use of this gas, especially in enclosed spaces such as in pits or closed rooms.

Keep refrigerant containers covered and closed.

Keep the centrifuge cover closed if in use, especially when using the refrigeration mode of operation. This will prevent frosting and ice formation, and also save costly energy.

3.4 Operating Procedure

Operating procedure includes: (1) precooling, (2) opening the cover, (3) installing the rotor, (4) loading the rotor, (5) closing the cover, (6) programming the run cycle, (7) starting the run cycle, (8) stopping the run cycle, (9) changing modes during operation, (10) determining relative centrifugal force (RCF) and (11) removing the rotor.

3.4.1 Precooling

These paragraphs describe the optimum temperature-controlling procedures under the following conditions:

- Precooled Chamber/Precooled Rotor and Accessories.
- Warm (ambient) Chamber/Warm Rotor Accessories.
- Warm Chamber/Precooled Rotor and Accessories.
- Changing Temperature Settings.
- Precooling Material (sample).
- Changing from Horizontal-to-Angle Rotor (or vice versa).

3.4.1.1 Precooled Chamber/Precooled Rotor and Accessories

If the chamber, rotor and accessories are already precooled, continue operation as described in Paragraph 3.4.3.

3.4.1.2 Warm Chamber/Warm Rotor and Accessories

- A. Open the cover as described in Paragraph 3.4.2.
- B. Install and load the rotor with its accessories ONLY (no sample material) as described in Paragraphs 3.4.3 and 3.4.4.
- C. Close and lock the cover. The cover knob must be fully CCW.
- D. Set the TEMP^oC control to the desired temperature.
- E. Set the RPM control to 1000.
- F. Set the TIMER control to 20 minutes.
- G. Push the START button.
- H. Allow the chamber to cool for approximately 20 minutes.
- I. Set the RPM control to the maximum allowable speed (Refer to Table 3-2) for the selected accessory combination.
- J. Set the RPM, TIMER and BRAKE controls to the desired positions as described in Paragraph 3.4.6.
- K. Press the START button to start the run cycle as described in Paragraph 3.4.7.

3.4.1.3 Warm Chamber/Precooled Rotor and Accessories

- A. With the chamber empty, set the POWER switch to the ON position; keep the cover closed.
- B. Set the TEMP^oC control to the desired temperature.
- C. Allow the refrigeration system to run for approximately 15 minutes.
- D. Open the cover. Install the rotor and its accessories ONLY (no sample material) into the chamber as described in Paragraphs 3.4.3 and 3.4.4. Close and lock the cover.

E. Set the RPM control to the maximum allowable speed for the selected accessory combination. (Refer to Table 3-2).

F. Press the START button.

G. Allow the refrigeration system to cycle on-and-off about the set temperature for approximately ten minutes.

H. Push the STOP button and the BRAKE button.

I. When the STOP button lights, open the cover. Load the sample material into the rotor accessories.

J. Close and lock the cover.

K. Set the RPM, TIMER and BRAKE controls to the desired positions as described in Paragraph 3.4.6.

L. Press the START button to start the run cycle as described in Paragraph 3.4.7.

3.4.1.4 Changing Temperature Settings

CAUTION

If power is removed for any reason wait at least one minute before starting up the refrigeration system again. Also, if the temperature setting is to be changed from a higher to a lower one, turn the TEMP^oC control to +30^oC setting first, then wait approximately one minute before setting the control to the desired temperature. Otherwise, the head pressure in the refrigeration compressor will not be stabilized and compressor damage may result.

A. Prior to loading the sample material into the rotor accessories, set the TEMP^oC control to the new temperature setting. Close and lock the cover.

B. Set the RPM control to 1000 and set the TIMER to the HOLD position.

C. Press the START button.

D. When the refrigeration system starts cycling on-and-off, set the RPM control to the maximum allowable speed. Set the TIMER to ten minutes.

E. When the STOP button lights, open the cover. Load the sample material into the rotor accessories.

F. Close and lock the cover.

G. Set the RPM, TIMER and BRAKE controls to the desired positions as described in Paragraph 3.4.6.

H. Press the START button to start the run cycle as described in Paragraph 3.4.7.

3.4.1.5 Precooling Sample Material

For accurate temperature measurement small (less than 50 ml) amounts of sample material should be precooled to within $\pm 5^{\circ}\text{C}$ of the desired temperature prior to loading into the rotor accessories.

Large (50 ml or more) amounts of sample material should be precooled to within $\pm 2^{\circ}\text{C}$ of the desired temperature prior to loading into the rotor accessories.

However, in order to maintain accurate temperature readings the thermometer used to measure sample temperatures must also be precooled. Otherwise the heat from the thermometer body will increase the temperature of the sample material. This pertains to both small and large amounts of sample material but especially to the small amount.

This may be accomplished as follows:

When less than a full complement of tubes is to be centrifuged, select two opposite holes in the rotor as sites for tubes to be used for temperature measurement purposes.

Fill two tubes with a 50/50 water/alcohol solution and balance and load these temperature-check tubes symmetrically into the two opposite holes in the rotor.

Insert the thermometer into one of the temperature-check tubes. Keep the thermometer in the tube for at least 20 seconds. Then put the thermometer into the second temperature-check tube. Check the temperature of the thermometer; this reading will be representative of the sample temperature.

When a full complement of tubes is to be centrifuged, precool the thermometer ($\pm 0.5^{\circ}\text{C}$ for small, $\pm 2^{\circ}\text{C}$ for large, amounts of sample material) then immerse the thermometer into the sample for at least 20 seconds.

3.4.1.6 Changing from Horizontal-To-Angle Rotor (or vice versa)

CAUTION

If power is removed for any reason, wait at least one minute before starting up the refrigeration system again. Also, if the temperature setting is to be changed from a higher to a lower one, turn the TEMPOC control to $+30^{\circ}\text{C}$ setting first, then wait approximately one minute before turning the control to the desired temperature setting. Otherwise, the head pressure in the refrigeration compressor will not be stabilized and compressor damage may result.

A. Load warm rotor with accessories into chamber. If desired, new temperature may be set at this time also.

B. Set the RPM control to 1000 and set the TIMER to the HOLD position.

C. Press the START button.

D. When the refrigeration system starts cycling on-and-off, set the RPM control to the maximum allowable speed (refer to Table 3-2). Set the TIMER to ten minutes.

E. When the STOP button lights, open the cover. Load the sample material into the rotor accessories.

F. Close and lock the cover.

G. Set the RPM, TIMER and BRAKE controls to the desired positions as described in Paragraph 3.4.6.

H. Press the START button to start the run cycle as described in Paragraph 3.4.7.

3.4.2 Opening The Cover

A. Set the POWER switch to ON. The POWER and STOP indicators will illuminate. The cover interlock solenoid will release the latch (you will hear a click) from the solenoid as it holds the latch in a released position.

B. Turn the cover knob CW one-quarter turn and open the cover.

NOTE: If there is a power failure, or other emergency, the cover may be opened quickly as described in Paragraph 3.7.

3.4.3 Installing The Rotor

These rotors are secured to the drive motor shaft by a hex-shaped nut IEC Part No. 47114, supplied with the machine. This hex nut is tightened or loosened by means of a wrench, IEC Part No. 1787, also supplied. Before placing the rotor onto the shaft, remove the hex nut, then be sure that the tapered hole in the rotor and the taper of the shaft are clean.

Taking care not to damage the threads, carefully lower the rotor onto the shaft, then tighten the hex nut down to secure the rotor to the motor shaft.

NOTE: Do NOT use any other tool to tighten the hex nut as overtightening could occur and the threads could be damaged.

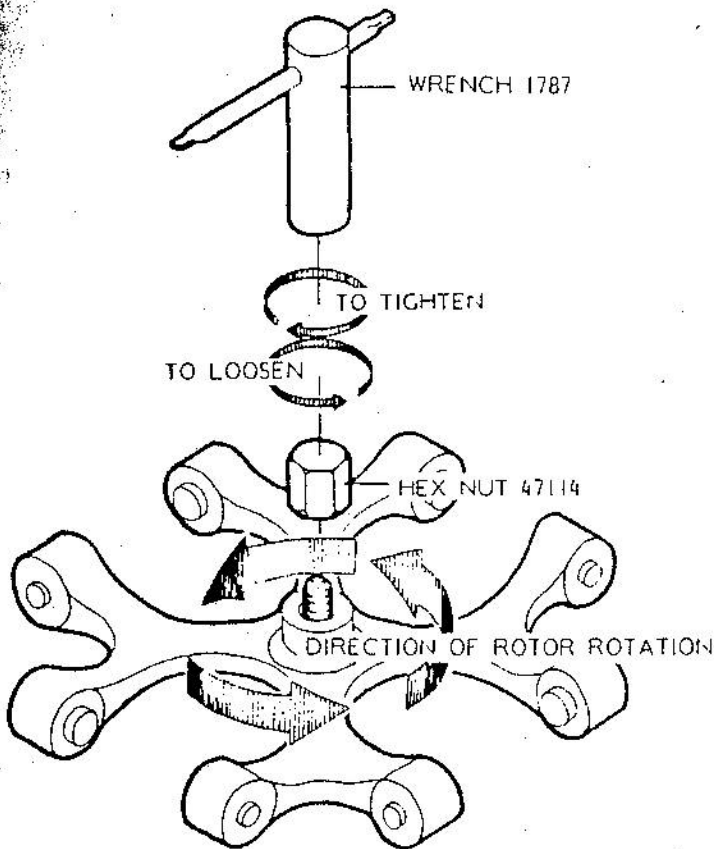

FIGURE 3-2 INSTALLING ROTOR

3.4.4 Loading The Rotor

If in normal laboratory use constant vibration is noted, it may be traceable to the imbalance of the load in the rotor. You should ensure that the rotor is loaded symmetrically and with a full complement of accessories and

that the total load combination of shields, trunnion rings, cups and/or carriers are within 0.5 grams of each other. Also check that each shield has a proper cushion and make sure that all shields contain one cushion.

CAUTION: NEVER USE MERCURY IN CUPS OR SHIELDS FOR BALANCING PURPOSES.

IT IS ESSENTIAL THAT ONLY IEC ROTORS AND ACCESSORIES BE USED ON THIS CENTRIFUGE.

Accessory balance is also an important factor in prolonging the bearing and armature life of the drive motor. IEC rotors, as well as all rotating parts of this centrifuge, are dynamically balanced at the factory. In addition IEC trunnion rings, shields, cups and carriers are weighed and matched to one-half of a gram. The gram weight is stamped on each piece.

All horizontal and angle rotors should be loaded with a full complement of accessories to prevent unequal stresses on the rotor during operation.

CAUTION: NEVER OPERATE THE CENTRIFUGE WITHOUT A ROTOR SECURED TO THE SHAFT.

To obtain a good dynamic balance the opposite loads must, in addition to being equal in mass, have the same center of gravity. Care should be taken to select tubes and bottles in pairs that are alike in shape, thickness and distribution of glass or plastic. The larger the container, the more critical the selection should be.

When measuring weight, use a laboratory balance with a sufficient capacity to handle the size container to be used and one which has a sensitivity of one-tenth of a gram at full load.

The following balancing technique renders the best possible weight distribution as well as providing maximum external support for the glassware/plasticware.

A. Place opposite cups containing filled glassware on the balance.

B. To the lighter centrifuge cup add water (or a 50/50 mixture of water/alcohol for refrigerated runs) around the glassware/plasticware but no closer to the top of the container than one-quarter inch.

C. Add water (or a 50/50 mixture of water/alcohol for refrigerated runs) to the other centrifuge cup until the two are in good balance.

NOTE: If the use of water/alcohol is not desired, such as with blood bags, the use of rubber discs, small pieces of soft plastic, or tubing is suggested.

CAUTION: Mercury should never be placed in cups or shields for balancing.

IMPORTANT: All centrifuges have critical speeds at which vibration occurs. As the speed increases beyond the critical speed vibrations will cease. This inherent condition also occurs during deceleration.

An imbalanced load intensifies these critical frequencies. **DO NOT OPERATE THE CENTRIFUGE CONTINUOUSLY AT OBSERVED CRITICAL FREQUENCIES.**

D. Close and lock (handle fully CCW) the cover.

3.4.5 Closing The Cover

The cover should be kept closed, especially when making refrigerated runs. This will help to prevent condensation and save energy.

Lower the cover. Turn the cover knob CCW one-quarter turn to lock the cover.

3.4.6 Programming The Run Cycle

A. Set the TEMP°C control to obtain the desired temperature.

B. Set the RPM control to obtain the desired speed. Refer to the Speed, RCF and Accessory Table (3-2).

C. Set the TIMER to the desired run duration or to the HOLD position if the run is not to be timed.

D. Set the BRAKE control to the braking mode or to the OFF (coast) position. This completes the programming of the run cycle.

3.4.7 Starting The Run Cycle

A. Push the START button to begin the run cycle.

B. The rotor will accelerate to the preselected time, and then decelerate according to the preselected braking mode.

3.4.8 Stopping The Run Cycle

The run cycle may be stopped at any time by depressing the STOP button or by setting the TIMER to OFF. Otherwise, the instrument will run for the preselected time and will come to a stop automatically according to the braking mode selected. The STOP indicator will light when the rotor is at rest. However, wait five seconds before opening the cover.

WARNING

DO NOT ATTEMPT TO STOP A MOVING ROTOR BY HAND.

3.4.9 Changing Modes During Operation

Any of the preselected modes, - speed, time, braking and partly temperature, - may be reset at any time during a run cycle. The temperature mode may also be reset to a higher (warmer) setting during a run. However, to change from a higher to a lower (cooler) temperature setting set the TEMP°C control to +30°C first, then wait about one minute before setting the control to the desired temperature and attempting to start the refrigeration again. Otherwise, the head pressure in the refrigeration compressor will not be stabilized and compressor damage may result.

Also, if the timer is reset by setting the timer from the OFF position to the HOLD position (or from the HOLD position to the OFF position) it may be necessary to push the RUN button again to resume the run.

3.4.10 Determining Relative Centrifugal Force (RCF)

The RCF in gravities (G's) may be determined by means of the IEC nomograph which is shown in Table 3-1.

3.4.11 Removing The Rotor

- A. Open the cover.
- B. Use the IEC Part No. 1787 wrench to turn (CCW) and loosen the hex nut. Remove the nut.
- C. Use both hands to keep the rotor horizontal then pull the rotor up and off the shaft. If difficulty is encountered replace the hex nut on the shaft and turn it down several turns. Use the top of the wrench to lightly tap the hex nut while pulling upward on the rotor to loosen it from the shaft. Remove the hex nut and carefully lift the rotor off the shaft.
- D. Close the cover.

3.5 Care And Cleaning of IEC Rotors And Structural Accessories

In order to prevent corrosion and subsequent replacement these procedures should be followed:

3.5.1 Corrosion

CAUTION

An important precaution to be taken by the operator of a centrifuge is to prevent the corrosion of rotors and structural accessories (shields, trunnion rings, cups and carriers). These parts are manufactured by IEC and are properly finished and checked by Quality Control facilities before they leave the factory. Every possible consideration has been exercised to provide the maximum resistance to corrosion. However, it is essential for proper operation and safety that the operator continue a high standard of preventive maintenance to maintain maximum resistance to corrosion. If corrosion is allowed to continue, small cavities will form within the part which will grow deeper with continuous operation resulting in eventual failure.

3.5.2 Inspection

Before and after each run, the parts should be routinely examined for corrosion and cracks. Particular attention should be given to the inside and bottom of rotor cavities, shields and cups, and to the inside surfaces and corners of rack and multiple type carriers. If these conditions are discovered, discontinue the use of the part immediately and consult IEC.

3.5.3 Prevention

The hazard of corrosion can be completely eliminated by conscientious operator technique. After each run the part should be rinsed in warm tap water and finally in distilled water. If material is spilled into the part it should be washed out with a mild hand-washable liquid detergent solution and the cavities scrubbed with a stiff test tube brush having end bristles and a non-metallic tip. The part should be rinsed in warm tap water and finally in distilled water. When particularly caustic materials are run this procedure should be carried out immediately upon termination of the run.

3.5.4 Drying

After the part has been thoroughly cleansed it is important to dry it properly, preferably by wiping with a clean, absorbent towel. A drying oven may be used, but the temperature should not exceed 80°C. Angle rotors should be stored open to the atmosphere with cavities down and horizontal rotors turned upside down so that the most surface area is exposed. Shields, cups, and carriers should have their cavities exposed to the atmosphere. Parts should be stored on a soft surface to prevent damage to anodized or other finished surfaces. After the proper cleaning and drying procedures have been followed, store the part clean and dry at room temperature. Parts should not be stored wrapped in a plastic bag.

3.5.5 Corrosion Removal

If surface corrosion occurs, it is of the utmost importance to remove it immediately. The following procedure is recommended.

A. The part should be soaked to remove deposits from the metal surface. Use a mild, non-alkaline, hand-washable liquid 1% detergent solution. Do not use soaps or detergents which contain alkalis. (Most laboratory detergents are too caustic to use on anodized or lacquered finishes.)

B. Scrub the part thoroughly with a stiff test tube brush having end bristles and a non-metallic tip. Pay close attention to the bottom of the tube carriers and to multiple carriers.

C. Allow the part to soak again in clear, warm water for a minimum of one hour.

D. Rinse the part thoroughly in warm water first then rinse it again in distilled water.

E. Dry the part thoroughly with a clean absorbent cloth.

F. If corrosion is deep and cannot be removed with a tube brush the unit may be unsafe. Discard the item and order a replacement with the same gram weight from your authorized dealer.

3.6 Cleaning The Centrifuge

The centrifuge should be maintained in a clean, uncluttered condition to ensure satisfactory operation and to increase service life. Check often for condensation within the centrifuge. Too much condensation will result in lower rotor speeds. Remove condensation with a clean sponge. The following procedure is recommended:

A. Unlatch and open the cover of the centrifuge. Remove the rotor.

B. ALWAYS UNPLUG THE POWER CORD FOR SAFETY DURING CLEANING.

C. Check the guard bowl for spillage or broken glass. Remove glass with a vacuum cleaner if possible. Remove liquids and clean the bowl with a damp sponge (See Step D). Remove and discard all rubber cushions in accessories and replace in case of glass

breakage. Gray dust is the result of finely-ground glass. This must be removed to ensure satisfactory motor life, to prevent sample contamination, and to prevent abrasion of the inside surfaces.

D. Clean the inside of the guard bowl and then the outside of the cabinet using a moist (not wet) sponge, with warm water and a mild, hand-washable liquid detergent. Repeat using clear, warm water.

E. Observe the following precautions at all times:

(a) Never use an abrasive cleaner or steel wool pads. If there are stubborn stains, remove them with plastic scrub pads.

(b) Never pour water or any liquid into the guard bowl chamber. Otherwise it will flow into electrical parts.

(c) Do not use strong oxidents, aromatic solvents, esters, ketones, or chlorinated solvents when cleaning the centrifuge cover. **WARNING:** When the cleanup involves hazardous, contaminated or radioactive material, wear rubber gloves and take any other precautions appropriate to the hazards involved. Contact laboratory safety personnel for detailed information.

(d) Dry the chamber guard bowl thoroughly.

(e) Wipe the outside of the centrifuge clean and remove any water that may have spilled on the floor.

TABLE 3-1
NOMOGRAPH FOR COMPUTING RELATIVE CENTRIFUGAL FORCE

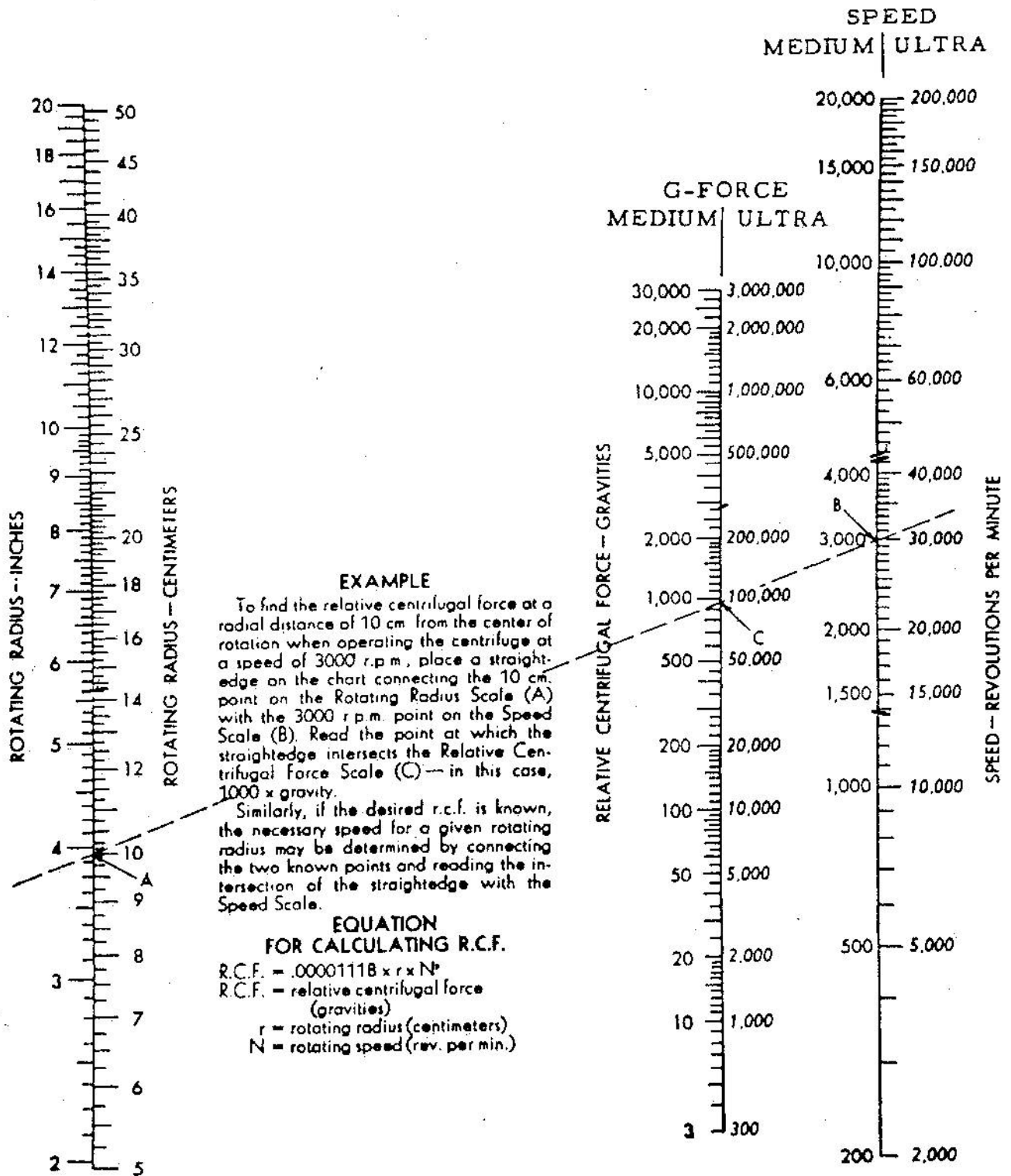

INTERNATIONAL EQUIPMENT COMPANY
 A DIVISION OF DAMON
 300 SECOND AVE., NEEDHAM HTS., MASS. 02194, TEL. (617) 449-0800
 TELEX 92-2499, INTLEQUIP NEDM, CABLE: INTERCO-BOSTON

IMPORTANT

ROTOR DERATING FACTORS vs. SPECIFIC GRAVITY OF ROTOR CONTENTS

All International Equipment Company horizontal and angle rotors are provided with an unlimited operational warranty, excluding mishandling, and never require derating due to hourly or cyclic use provided that corrosion is eliminated and rotor contents do not exceed maximum allowable specific gravity.

Maximum specific gravity permissible without derating is 1.2 in horizontal (swinging bucket rotors) and 1.5 in angle rotors. For specific gravities in excess of 1.2 in a horizontal rotor or 1.5 in an angle rotor, the published speed must be multiplied times the derating factor corresponding to the average specific gravity of the tube plus contents. RPM (allowable) = RPM (Maximum) x derating factor.

The chart below indicates the derating factor for specific gravities from 1.2 to 3.0 in specific gravity increments of .10.

<u>SPECIFIC GRAVITY</u>	<u>HORIZONTAL ROTORS</u>	<u>ANGLE ROTORS</u>
1.20	---	---
1.30	.960	---
1.40	.925	---
1.50	.894	---
1.60	.866	.967
1.70	.839	.939
1.80	.816	.912
1.90	.794	.888
2.00	.774	.866
2.10	.755	.844
2.20	.738	.825
2.30	.721	.807
2.40	.707	.790
2.50	.692	.774
2.60	.678	.758
2.70	.666	.744
2.80	.654	.731
2.90	.642	.719
3.00	.632	.707

This table is based on the formula:

$$D.F. = \sqrt{\frac{\text{Max. SP. GR. permissible without derating}}{\text{Actual SP. GR.}}}$$

and may be utilized to calculate derating factors for specific gravities greater than 3.0

$$RPM \text{ (allowable)} = RPM \text{ (Maximum)} \times D.F.$$

3.7 Cover Interlock Mechanical Safety Bypass

This centrifuge protects the user by locking the cover closed during operation. This safety feature may be bypassed only in emergencies such as in a power failure.

- Use a small screwdriver to carefully pry the top corners of the panel out enough to grip the top edge of the panel. Pull the panel off the three upper retaining prongs.
- Lift the panel up enough to clear two retaining tabs at the bottom of the panel.
- Locate the cover interlock release. Use a screwdriver to press down on the release while you turn the knob clockwise. This will release the cover.

- Replace the front panel.

3.8 Brush Removal and Replacement

1. Open the centrifuge cover. Set the Power switch to the OFF position. Unplug the centrifuge power cord.
2. Remove the motor boot by removing the six screws.
3. Identify both brush caps located on the upper end of the drive motor.
4. Use a screwdriver to remove the brush caps.

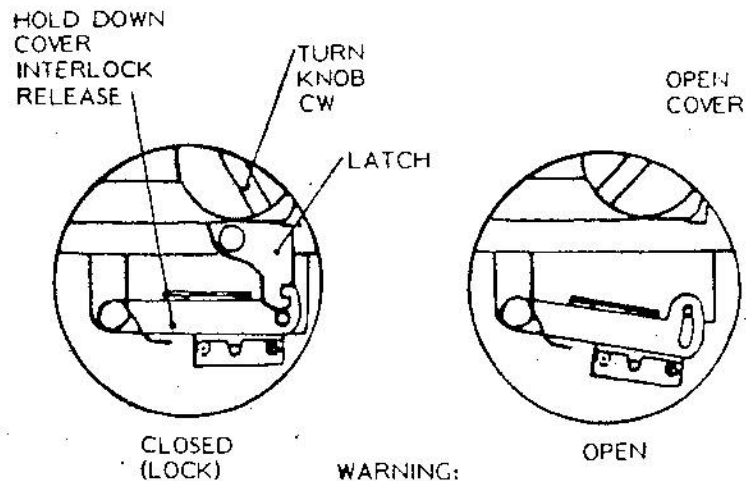
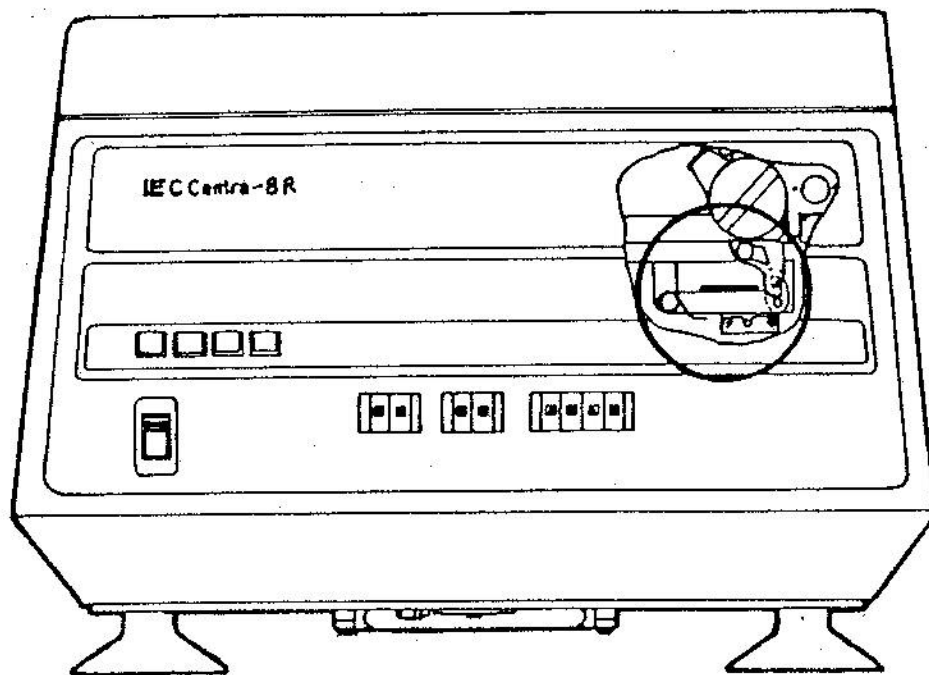

WARNING:
DO NOT USE FINGERS
LATCH MAY PINCH

Figure 3-3 Cover Interlock Bypass

5. Carefully remove the brushes and inspect them. Each brush is complete with a carbon contactor, a spring, a copper connector wire and an end cap. Brush contactors should be replaced when less than 1/4 inch long.

CAUTION: The commutator revolves in a counter-clockwise direction as viewed from above. Replacement of inspected brushes must be inserted in the same position that they were removed to assure long brush life and satisfactory motor operation. The trailing edge of the brush (CCW) may be identified by the presence of a dark deposit of carbon along the side of the brush adjacent to that edge.

6. Inspect the commutator as described in Paragraph 3.9.

7. Inspect the brush to be installed. Use IEC brushes only. Brushes must not be damaged or have broken copper connector wires. The spring should not be fatigued or broken. The brush Part Number is 49801.

Insert each brush into the holder and align end caps to rectangular slot. Screw in brush caps carefully. Ensure that end caps freely engage the brush holder.

8. Replace the motor boot and secure it in place with the six screws.

IMPORTANT: When replacing brushes, order a spare set.

3.9 Commutator Inspection

Inspect the commutator when brushes are being inspected or replaced, or whenever there is a question as to commutator condition. Use a dial gage to check that maximum commutator radial runout is 0.001".

NOTE: Severe arcing with new brushes is an indication of a bad commutator.

1. Remove the motor boot as described in Paragraph 3.8.

2. Use a flashlight or an extension light to inspect the commutator through the top ventilating holes of the motor. If the commutator is excessively grooved, or worn, replace the motor.

3. Replace the motor boot as described in Paragraph 3.8.

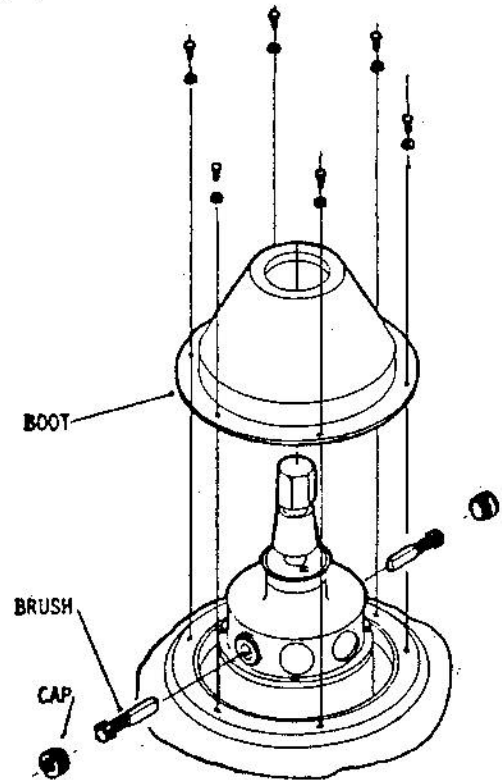

Figure 3-4 Brush Replacement

CAUTION WHEN RE-INSTALLING INSPECTED BRUSHES

When brush replacement is not required, it is important that the brush be inserted in the same position as it was removed. The trailing edge of the brush must be positioned as follows (looking from above).



The trailing edge may be identified by the presence of a dark deposit of carbon along that side.

3.10 Fuse Replacement

The main power circuit is protected by an eight, or ten-ampere slow blow fuse.

If the operating voltage is 100 or 120 VAC then the fuse is a 15-ampere fuse, Part Number 47868.

If the operating voltage is 200, 220 or 240 VAC, then the fuse is a ten-ampere fuse, Part Number 47057. The main power fuse is located next to the power cord at the lower left, rear corner of the centrifuge. The fuseholder cap will glow when the fuse is bad.

A five-volt power supply circuit is protected by a 100 milliampere slow-blow in-line fuse, Part Number 49225. This fuse is located on the rear of the front panel.

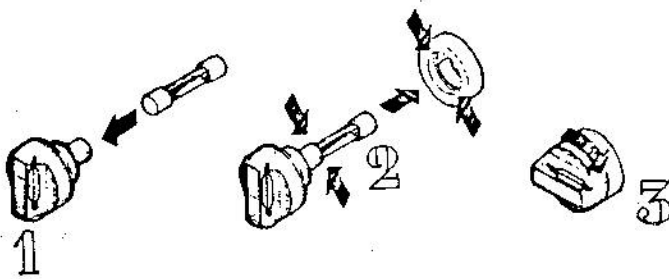

Figure 3-5 Main Fuse Replacement

3.10.1 Main Power Fuse

A. REMOVAL

The fuseholder cap will glow when the fuse is bad.

1. Set the Power switch to the OFF position.
2. Unplug the power cord.
3. Locate the fuse next to the power cord at the rear of the unit.
4. Push the fuseholder cap in and turn it counter-clockwise.
5. Pull the cap holding the fuse out of the fuseholder.

6. Separate the bad fuse from the cap. Keep the cap.
7. Remove the front panel.
8. Locate and remove the spare fuse from the plastic bag which is taped to the base assembly. Order a new fuse at this time.
9. Replace the front panel.

B. REPLACEMENT

1. Insert the new fuse into the fuseholder cap.
2. Insert the cap into the fuseholder. Turn the cap clockwise to lock it in place.
3. Plug the power cord in.

3.10.2 Five Volt Power Supply Fuse

A. REMOVAL

1. Set the Power switch to the OFF position.
2. Unplug the power cord
3. Remove the front panel.
4. Locate the in-line fuse on the rear of the front panel.
5. Push the fuseholder cap in and turn it counter-clockwise. NOTE: The cap and the fuse are one assembly and are replaced together. The assembly part number is 49225.

B. REPLACEMENT

1. Insert the new cap and fuse assembly into the fuseholder.
2. Turn the cap clockwise to lock it in place.
3. Replace the front panel.
4. Plug the power cord in.