

Operating Instructions

Sartorius M-pact Series

Electronic Analytical and Precision Balances

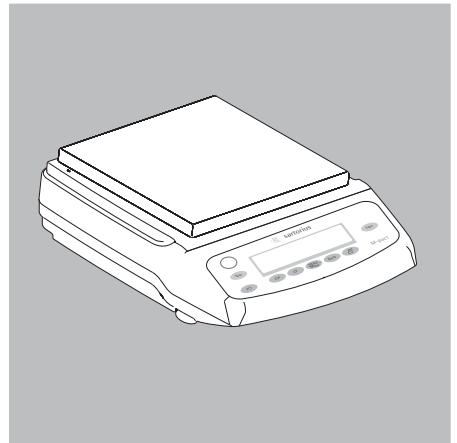
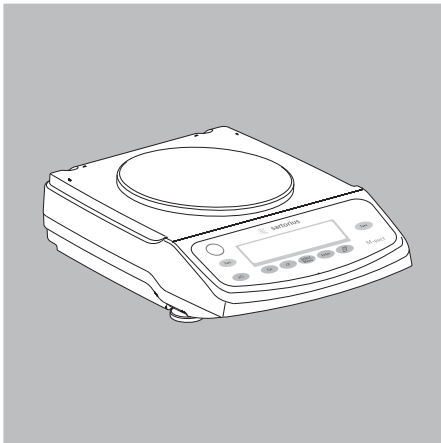
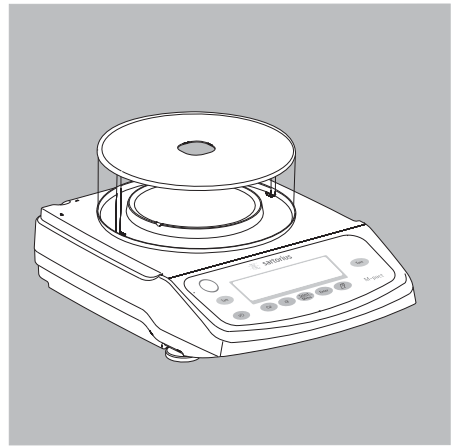
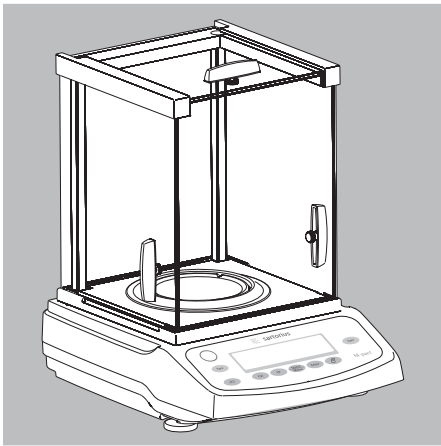

Contents

Warnings and Safety Precautions	4
Getting Started	5
Installation	6
Leveling the Balance	10
Below-Balance Weighing	11
Operation	12
Display and Operating Elements	12
Basic Weighing Function	13
Calibration and Adjustment	14
Configuration (Operating Menu)	17
Functions of the Keys during Configuration	17
Menu Navigation; Example: Setting the Language	18
Parameter Settings: Menu	19
Parameter Settings: Overview	20
Application Programs	26
Counting	26
Weighing in Percent	28
Calculation	30
Animal Weighing/Averaging	32
Net-total Formulation	34
Totalizing	36
Mass Unit Conversion	38
Density Determination	40
ISO/GLP-compliant Printout/Record	43
Data Interface	45
Troubleshooting Guide	46
Care and Maintenance	47
Recycling	48
Overview	49
Specifications	49
Accessories	52
EC Declaration of Conformity	54

Symbols

The following symbols are used in these instructions:

- indicates required steps
- indicates steps required only under certain conditions
- > describes what happens after you have performed a particular step
- indicates an item in a list
-  indicates a hazard

Warnings and Safety Precautions

Safety

- To prevent damage to the equipment, please read these operating instructions carefully before using the balance.



Do not use this equipment in hazardous areas.



The balance may be opened only by trained service technicians.



Disconnect the balance from power before connecting or disconnecting peripheral devices.



If you operate the balance under ambient conditions subject to higher safety standards, you must comply with the applicable installation regulations.



Exposure to excessive electromagnetic interference can cause the readout value to change. Once the disturbance has ceased, the instrument can be used again in accordance with its intended purpose.

Make sure that no liquid enters the equipment housing; use only a slightly moistened cloth to clean the balance.

Installation



Make sure the voltage rating printed on the power supply is identical to your local line voltage.

- Proceed with extreme caution when using pre-wired RS-232 connecting cables, as the pin assignments may not be compatible with Sartorius equipment. Before connecting the cable, check all pin assignments against the cabling diagrams and disconnect any lines that are assigned differently.



If there is visible damage to the equipment or power cord, disconnect the equipment from power and lock it in a secure place to ensure that it cannot be used for the time being.

- Connect only Sartorius accessories and options, as these are optimally designed for use with your balance. The operator shall be solely responsible for installation and testing of any modifications to Sartorius equipment, including connection of cables or equipment not supplied by Sartorius. On request, Sartorius will be happy to provide information on operating specifications (in accordance with the Standards for defined immunity to interference).
- Do not open the balance housing. If the seal is broken, this will result in forfeiture of all claims under the manufacturer's warranty.
- If you have any problems with your balance, contact your local Sartorius customer service center.

Getting Started

Storage and Shipping Conditions

- Do not expose the balance to extreme temperatures, moisture, shocks, blows or vibration.

Unpacking the Equipment

- After unpacking the equipment, please check it immediately for any external damage.
- If you detect any damage, proceed as directed in the chapter entitled “Care and Maintenance,” under “Safety Inspection.”
- Save the box and all parts of the packaging for any future transport. Disconnect all cables before packing the balance for shipping.

Equipment Supplied

- Balance
- Weighing pan
- Pan support (only for models with a round weighing pan)
- AC adapter with country-specific power cord

Additional equipment supplied with models AX224, AX124:

- Draft shield chamber with sliding doors
- Shield ring
- Shield plate
- Dust cover

Additional equipment supplied with models AX623, AX423:

- Draft shield chamber with sliding doors

Installation

Choose a location that is not subject to the following negative influences:

- Heat (heater or direct sunlight)
- Drafts from open windows and doors
- Excessive vibration during weighing
- Excessive moisture

Conditioning the Balance

Moisture in the air can condense on cold surfaces whenever the equipment is moved to a substantially warmer place. To avoid the effects of condensation, condition the weighing instrument for 2 hours at room temperature, leaving it unplugged from AC power.

Installation

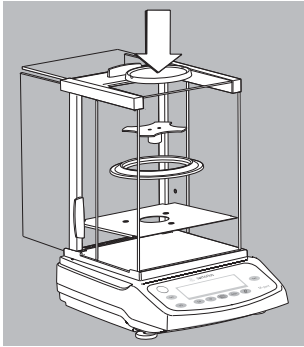

Setting Up the Balance

Instruments with sliding-door draft shield chamber:

- Place components inside the chamber in the following order:
 - Shield plate
 - Shield ring
 - Pan support
 - Weighing pan

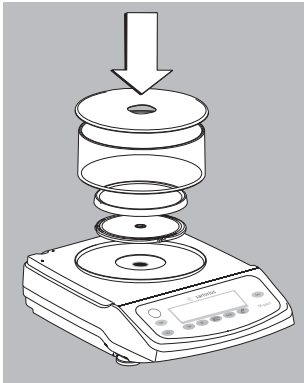

Instruments with a round glass draft shield:

- Position the components listed below in the order given:
 - Place the lower lid on the balance/scale with the raised edge facing upwards and turn it until it is firmly in position
 - Pan support
 - Weighing pan
 - Glass draft shield
 - Place the upper lid on the draft shield with the raised edge facing downwards

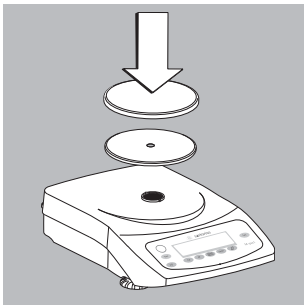

Instruments with a round weighing pan

- Position the components listed below in the order given:
 - Pan support
 - Weighing pan

Instruments with a rectangular weighing pan:

- Place the weighing pan on the balance, so that the rubber guide elements underneath the weighing pan fit exactly into the holes on the pan support.

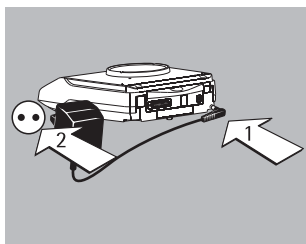

Connecting the Balance to AC Power

Use only original Sartorius AC adapters.
For use within Europe: part no. 6971412

- 1) Connect the angle plug to the balance
- 2) Connect the AC adapter to the wall outlet (mains)

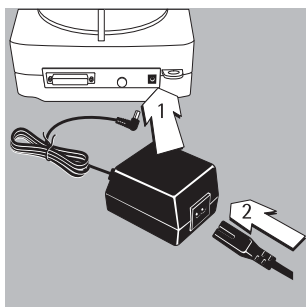

AC Adapter with Country-specific Power Cord

Some models come with separate country-specific power cords for the AC adapter. In India, use only original Sartorius AC adapter part no. 6971983.

- 1) Connect the angle plug to the balance
- 2) Select the power cord for your area and connect it to the AC adapter
- 3) Plug the power cord into the wall outlet (mains)

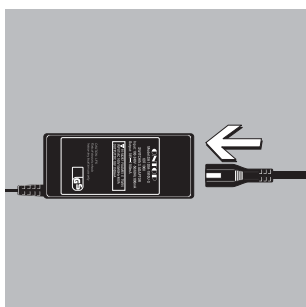

Use an original Sartorius AC adapter with a wide input voltage range (100 to 240 V~), order no. 6971966, and replaceable power cord:
6900900 (Europe, Indonesia, Vietnam)
6900901 (US/CDN, Philippines, Thailand, Taiwan)
6900905 (Australia, New Zealand)
6971945 (UK, Hong Kong, Malaysia, Singapore)
6971964 (India)
6971978 (China)

Safety Precautions

Plug-in AC Adapter 6971412 and Benchtop AC Adapter 6971983: The AC adapter rated to Class 2 can be plugged into any wall outlet without additional safety precautions.

Benchtop AC Adapter 6971966:

The AC adapter rated to Class 1 can be plugged into any wall outlet without additional safety precautions.

The ground terminal is connected to the balance housing, which can be additionally grounded for operation. The data interface is also electrically connected to the balance housing (ground).

NOTE: This equipment has been tested and found to comply with the limits pursuant to part 15 of FCC Rules.

These limits are designed to provide reasonable protection against harmful interference. This equipment generates, uses and can radiate radio frequency energy and, if not installed and used in accordance with these instructions, may cause harmful interference to radio communications.

For information on the specific limits and class of this equipment, please refer to the Declaration of Conformity. Depending on the particular class, you are either required or requested to correct the interference.

If you have a Class A digital device, you need to comply with the FCC statement as follows: "Operation of this equipment in a residential area is likely to cause harmful interference in which case the user will be required to correct the interference at his own expense."

If you have a Class B digital device, please read and follow the FCC information given below:

"However, there is no guarantee that interference will not occur in a particular installation. If this equipment does cause harmful interference to radio or television reception, which can be determined by turning the equipment off and on, the user is encouraged to try to correct the interference by one or more of the following measures:

- Reorient or relocate the receiving antenna.
- Increase the separation between the equipment and receiver.
- Connect the equipment into an outlet on a circuit different from that to which the receiver is connected.
- Consult the dealer or an experienced radio/TV technician for help."

Before you operate this equipment, check which FCC class (Class A or Class B) it has according to the Declaration of Conformity included. Be sure to observe the information of this Declaration.

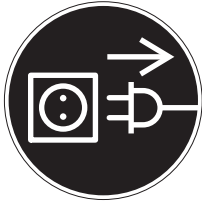

- Connecting Electronic Peripheral Devices**
- Make sure to unplug the balance from AC power before you connect or disconnect a peripheral device (printer or computer) to or from the interface port.

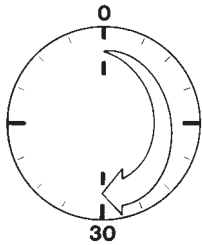

Warmup Time

To ensure accurate results, the balance must warm up for 30 minutes before operation. Only after this time will the instrument have reached the required operating temperature.

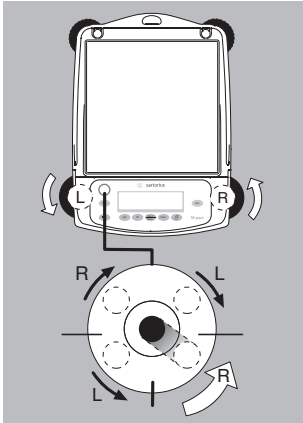

Leveling the Balance

Purpose:

- To compensate for unevenness at the place of installation

Always level the balance again any time after it has been moved to a different location. Only the 2 front feet are adjusted to level the balance.

- Retract the two rear feet (only on models with a rectangular weighing pan).
 - Turn the 2 front feet as shown in the diagram until the air bubble is centered within the circle of the level indicator.
- > In most cases this will require several adjustment steps.
- On models with a rectangular weighing pan: extend the 2 rear feet until they touch the surface on which the balance rests.

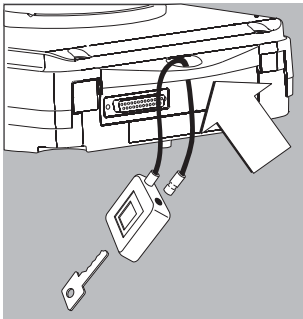

Anti-theft Locking Device

- To secure the balance at the place of installation, fasten a chain or a lock to the lug located on the rear panel of the balance.

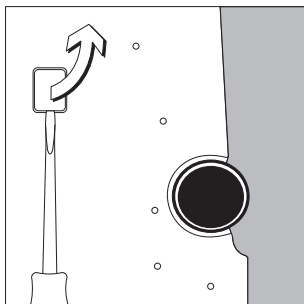

Below-Balance Weighing

A port for a below-balance weighing hanger is located on the bottom of the balance.

- Below-balance weighing is not permitted in legal metrology.
- Open cover plate on the bottom of the balance. Important: set the balance on its side to access the cover plate. DO NOT turn the balance upside-down.
- Using the built-in hook 1: Attach the sample (e.g., using a suspension wire) to the hanger.
- Install a shield for protection against drafts if necessary.

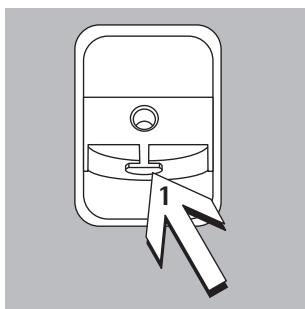

Operation

Overview of Display and Operating Elements

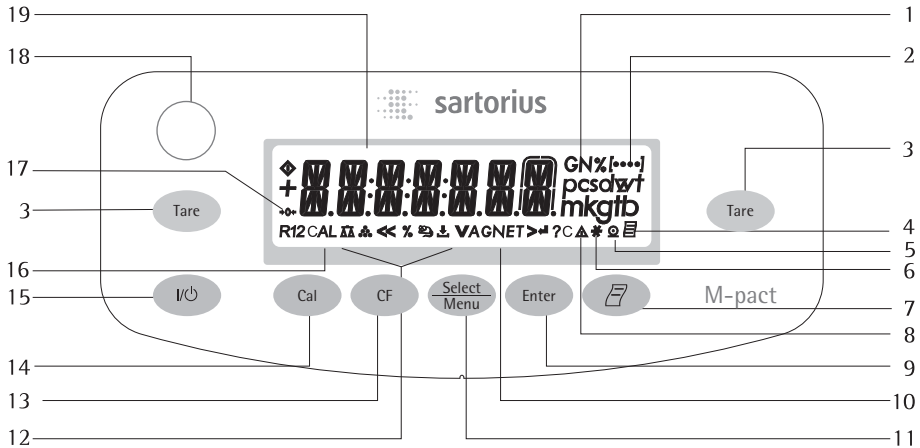

Position	Designation
1	Weight units
2	Menu level indicator
3	Taring
4	Symbol: "GLP printing mode active"
5	Symbol: "Printing mode active"
6	Symbol: "Application program active"
7	Data output: Press this key to send readout values to the built-in data interface.
8	Calculated-value indicator (i.e., not a weight value)
9	Start an application program
10	Symbol: Gross or net value
11	Select an application program Open the operating menu
12	Symbols for active application (Δ, Δ, %, %, ↓, A, C)



Position	Designation
13	Delete (Clear Function) This key is generally used to cancel functions: – Quit application program – Cancel calibration/adjustment routine Exit the operating menu
14	Start calibration/adjustment routine
15	On/off
16	Symbol: Calibration/adjustment function
17	Symbols for zero range (verified models only)
18	Level indicator
19	Weight value displayed in selected weight unit
Symbols:	
<<	Save settings and exit the operating menu
<	One menu level higher
∨	Scroll through menu items
>	Next item on current menu level
↓	Select a parameter setting

Basic Weighing Function

Features

- Taring the balance
- Printing weights

Preparation

- Switch on the balance: Press 
- Tare the balance, if necessary: Press 





- If necessary, change the configuration settings: see the chapter entitled “Configuration”
- If desired, load the factory settings: see the chapter entitled “Configuration”

Additional Functions

- Switching off the balance: Press 

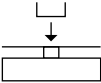
Example

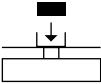
Simple Weighing

Step	Key (or instruction)	Display/Printout
1. Switch on the balance Self-test is performed, followed by automatic initial tare function.		0.0 g
2. Place container on weighing pan (in this example: 11.5 g).		+ 11.5 g
3. Tare the balance		0.0 g
4. Place sample in container (in this example: 132 g).		+ 132.0 g
5. Print weight.		N + 132.0 g

Calibration and Adjustment

Purpose

Calibration is the determination of any difference between the measured value displayed and the true weight (mass) of a sample. Adjustment is the correction of this difference, or its reduction to an allowable level within maximum permissible error limits.

Features

Calibration/adjustment can be performed only when:

- there is no load on the balance,
- the balance is tared, and
- the internal signal is stable.
- the weight displayed for the sample on the balance must not differ from the nominal weight by more than 2%.

If these conditions are not met, an error message is displayed ("ERR 02").

You can use any of the following weight units in calibration/adjustment:
CAL.UNIT: GRAMS, KILOGR. or POUNDS

For details on generating an ISO/GLP-compliant printout of calibration/adjustment results, see page 43.

Following calibration/adjustment, the application program is cleared.

Internal Calibration/Adjustment

In the operating menu, select *CAL.-ADJ.: CAL.INT.* before beginning. The built-in motorized calibration weight is applied and removed automatically for internal calibration.



- Select calibration/adjustment:
Press 
- > The built-in weight is applied automatically
- > The balance/scale is adjusted
- > The built-in calibration weight is removed.

Internal Calibration/Adjustment

Set the following parameters:

SETUP: BAL.SCAL.: CAL.-ADJ.: CAL.INT. (menu code 1.1.9.4)

The built-in motorized calibration weight is applied and removed automatically for internal calibration.



Step	Key (or instruction)	Display
1. Tare the balance/scale		0.0 g
2. Start calibration		<i>CAL.INT.</i>
The built-in weight is applied automatically		<i>CAL.RUN.</i>
3. Calibration/adjustment executed		<i>CAL.END</i>
4. The built-in weight is removed		0.0 g

External Calibration

Parameters (changes in factory settings):

SETUP: BAL.SCAL.: CAL.-ADJ.: CAL.EXT. (menu code 1.1.9.1)



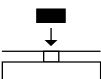
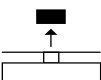



The required calibration weight is configured at the factory (see "Specifications")

Step	Key (or instruction)	Display
1. Tare the balance		0.0 g
2. Start calibration. Once you store the zero point the required calibration weight is prompted (flashing display)		CAL.EXT. 
3. Apply the prompted calibration weight (in this example: 5000 g) Weight too light: a minus sign "-" is shown Weight too heavy: a plus sign "+" is shown The display stops flashing as soon as the weight value is within the defined limit.		5000.0 g
4. Calibration/adjustment executed; then the calibration weight is displayed		CAL.END + 5000.0 g
5. Remove the calibration weight		0.0 g

Configuration (Operating Menu)











You can configure the balance; i.e., adapt it to individual requirements.

Functions of the Keys during Configuration

Symbol	Key	Function
V		Scroll through menu items
>		One menu level lower
↵		Confirm menu item
	 (press and hold)	Save settings and exit menu from any position
<<		Save settings and exit menu
<		One menu level higher
[••••]		Indicates menu level

Menu Navigation

Example: Setting the Language

Step	Key (or instruction)	Display
1. Open the menu: In weighing mode: first menu item is shown	 (hold)	APPLIC.
2. Scroll upward within the menu level; after the last menu code, the first code is displayed again	Repeatedly: 	INPUT ... LANGUAG.
3. Select menu level (scrolls to the right)		ENGLISH °
5. Change setting: Scroll until the desired setting is shown		ESPAÑOL
6. Confirm the menu code; “o” indicates the active setting		ESPAÑOL °
7. Return to the next higher menu level (from the fourth level)		LENGUA
○ Set other menu items as desired	 , 	
8. Save settings and exit menu	Repeatedly: 	
or		
○ Exit menu without saving changes		
> Restart your application		0.0 g

Parameter Settings: Menu







Level 1 [●]	Level 2 [●●]	Level 3 [●●●]	Menu code
SETUP	BAL.SCAL. Balance/balance parameters	AMBIENT Ambient conditions	1. 1. 1.
		APPFILT. Application filter	1. 1. 2.
		STAB.RNG. Stability range	1. 1. 3.
		TARING Taring	1. 1. 5
		AUTOZER. Auto zero	1. 1. 6
		WT.UNIT Basic weight unit	1. 1. 7.
		DISPLAY Display accuracy	1. 1. 8.
		CAL.ADJ. Function of the  key	1. 1. 9.
		CAL.UNIT Weight unit for calibration	1. 1. 11.
	INTERF. Interface	BAUD Baud rate	1. 5. 1.
		PARITY Parity	1. 5. 2.
		STOPBIT Number of stop bits	1. 5. 3.
		HANDSHK Handshake mode	1. 5. 4.
		DATABIT Number of data bits	1. 5. 5.
		BAT.REC. Output: SBI (ASCII) or printout	1. 5. 6.
	PRNT.OUT Settings for print function	PRINT (manual/automatic)	1. 6. 1.
		STOPAUT. Stop automatic printing	1. 6. 2.
		AUT.CYCL. Time-dependent autom. printing	1. 6. 3.
		TAR./PRT. Tare bal./balance after ind. print	1. 6. 4.
		PRT.INIT. Printout of appl. parameters	1. 6. 5.
		FORMAT Line format for printout	1. 6. 6.
		GLP ISO/GLP-compliant printout	1. 6. 7.
		TIME: 12/24 h	1. 6. 8.
		BATE: Format	1. 6. 9.
		MENU	1. 8. 1.
	EXTRAS Additional functions	SIGNAL Acoustic signal (beep)	1. 8. 2.
		KEYS Keypad	1. 8. 3.
EXT.KEY External switch function		1. 8. 4.	
ON.MODE Power-on mode		1. 8. 5.	
BACKLIT Display backlighting		1. 8. 6.	
MENU Factory settings		1. 9. 1.	
RESET			
APPLIC. Application programs	WEIGH		2. 1.
	UNIT Toggle wt. unit	DISP.DIG. Display accuracy	2. 2. 2.
	COUNT. Counting	RESOLUT. Resolution	2. 3. 1.
		REF.UPDT. Autom. ref. sample updating	2. 3. 2.
	PERCENT Weighing in percent	DEC.PLCS Decimal places	2. 4. 1.
	NET-TOT Net-total formulation	COMP.PRT. Printout of components	2. 5. 1.
	TOTAL Totalizing	COMP.PRT. Printout of components	2. 6. 1.
	ANIMALW. Animal weighing	ACTIVITY. Animal activity	2. 7. 1.
		START	2. 7. 2.
	CALC. Calculation	METHOD (operator)	2. 8. 1.
	DEC.PLCS Decimal places	2. 8. 2.	
DENSITY Density determination	DEC.PLCS Decimal places	2. 9. 1.	
INPUT Input	IDNO.	ID input; max. 7 characters	3. 1.
INFO Information	VERSION, SER.NO., MODEL	Display software ver., serial no., model	4. 1./2./3.
LANGUAG.	ENGLISH (factory setting)		5. 1.
	DEUTSCH (German)		5. 2.
	FRA.NC. (French)		5. 3.
	ITAL. (Italian)		5. 4.
	ESPAÑOL (Spanish)		5. 5.
	РУССКИЙ (Russian)		5. 6.
	POLSKI (Polish)		5. 7.
CODES Menu shows codes (not texts)		5. 8.	

Parameter Settings: Overview

o = Factory setting √ = User-defined setting

Level 1 [•]	Level 2 [••]	Level 3 [•••]	Level 4 [••••]	Menu code
SETUP	BAL.SCAL. Balance parameters	AMBIENT	√ STABLE Very stable	1. 1. 1. 1
		Ambient conditions (Filter adaptation)	o STABLE	1. 1. 1. 2
			UNSTABL	1. 1. 1. 3
			√ UNSTBL Very unstable	1. 1. 1. 4
		APP.FILT.	o FINAL RD. Final readout mode	1. 1. 2. 1
		Application filter	FILLING Filling mode	1. 1. 2. 2
		STAB.RNG.	1/4 DIG. (digit)	1. 1. 3. 1
		Stability range	1/2 DIG.	1. 1. 3. 2
			1 - DIGIT	1. 1. 3. 3
			o 2 - DIGIT	1. 1. 3. 4
			4 - DIGIT	1. 1. 3. 5
			8 - DIGIT	1. 1. 3. 6
		TARING	W/O STBW (o stability)	1. 1. 5. 1
		Taring	o W/ STAB After stability)	1. 1. 5. 2
		AUTOZER.	OFF	1. 1. 6. 1
		Auto zero	o ON	1. 1. 6. 2
		WT.UNIT	For list of units, see "Toggling between Weight Units"	1. 1. 7. 1
		Basic weight through unit		1. 1. 7. 23
		DISP.DIG.	o ALL	1. 1. 8. 1
		Display accuracy	MINUS 1	1. 1. 8. 2
			DIVIS. 1 1 interval	1. 1. 8. 6
		CAL./ADJ.	CAL. EXT. External cal./adj.	1. 1. 9. 1
		Function of the Cal key	o CAL. INT. Internal cal./adj.	1. 1. 9. 2
	BLOCKED Cal key blocked	1. 1. 3. 3		
CAL.UNIT. Unit for calibration weight	o GRAMS	1. 1.11. 1		
	KILOGR. Kilograms	1. 1.11. 2		
	POUNDS	1. 1.11. 3		

Level 1 [•]	Level 2 [••]	Level 3 [•••]	Level 4 [••••]	Menu code
SETUP	INTERF. Interface	BAUD rate	600	1. 5. 1. 3
			o 1200	1. 5. 1. 4
			2400	1. 5. 1. 5
			4800	1. 5. 1. 6
			9600	1. 5. 1. 7
			19200	1. 5. 1. 8
		PARITY Parity	o 0DD	1. 5. 2. 3
			EVEN	1. 5. 2. 4
			NONE	1. 5. 2. 5
		STOPBIT No. of stop bits	o 1BIT	1. 5. 3. 1
			2BITS	1. 5. 3. 2
	HANDSHK. Handshake mode	SFTWARE	1. 5. 4. 1	
		o HARDWARE	1. 5. 4. 2	
		NONE	1. 5. 4. 3	
	DATABIT No. of data bits	o 7BITS	1. 5. 5. 1	
		8BITS	1. 5. 5. 2	
	DAT.REC. Com- munication mode	5BI (ASCII)	1. 5. 6. 1	
		o PRINTER (GLP-printout)	1. 5. 6. 2	
	PRNT.OUT Printing fct.	PRINT (manual/ automatic)	MAN. W/O W/o stability	1. 6. 1. 1
			o MAN.WITH W/ stability	1. 6. 1. 2
			AUT. W/O Autom. w/o stability	1. 6. 1. 3
			AUT.WITH. Autom. w/ stability	1. 6. 1. 4
		STOPAUT. Stop automatic printing	o OFF Not possible	1. 6. 2. 1
ON Use print key 			1. 6. 2. 2	
AUT.CYCL. Time-dependent autom. printing		o EACHVAL (1 display update)	1. 6. 3. 1	
		AFTER 2 (2 display updates)	1. 6. 3. 2	
TAR./PRT. Tare the balance after individual printout		o OFF	1. 6. 4. 1	
		ON	1. 6. 4. 2	

Level 1 [●]	Level 2 [●●]	Level 3 [●●●]	Level 4 [●●●●]	Menu code
SETUP	PRNT.OUT Printing fct.	PRT.INIT.	OFF	1. 6. 5. 1
		Printing application parameters	o ALL All parameters	1. 6. 5. 2
			MAINPAR. Main parameters	1. 6. 5. 3
		FORMAT Line format for printout	16 CHAR. 16 characters (w/o ID)	1. 6. 6. 1
			o 22 CHAR. 22 characters (w/ ID)	1. 6. 6. 2
		GLP Printout as ISO/GLP-compliant	o OFF	1. 6. 7. 1
			CAL.-ADJ. Only for calib./adj.	1. 6. 7. 2
			ALWAYS All printouts	1. 6. 7. 3
		TIME	o 24H 24-hour format	1. 6. 8. 1
			12H 12-hour format "AM/PM"	1. 6. 8. 2
	DATE	o DD.MM.YY Day/month/year	1. 6. 9. 1	
		MM.DD.YY Month/day/year	1. 6. 9. 2	
	EXTRAS Additional functions	MENU	o CANEDIT Can change settings	1. 8. 1. 1
			RD.ONLY Read only	1. 8. 1. 2
		SIGNAL Acoustic signal	OFF	1. 8. 2. 1
			o ON	1. 8. 2. 2
		KEYS Keypad	o FREE	1. 8. 3. 1
			LOCKED	1. 8. 3. 2
		EXT.KEY Function of the external switch	o PRINT 	1. 8. 4. 1
			Z/TARE 	1. 8. 4. 2
			CAL. 	1. 8. 4. 3
			SELECT 	1. 8. 4. 4
			CF 	1. 8. 4. 5
ENTER 		1. 8. 4. 6		
ONMODE Power-on mode		o OFF/ON Off/on/standby	1. 8. 5. 1	
	STANDBY On/standby	1. 8. 5. 2		
	AUTO ON Auto on	1. 8. 5. 3		
BACKLIT Display backlighting	OFF	1. 8. 6. 1		
	o ON	1. 8. 6. 2		
RESET	MENU Reset menu	Factory settings	YES Restore fcty. settings	1. 9. 1. 1
			o NO Do not restore settings	1. 9. 1. 2











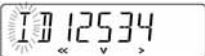

Level 1 [•]	Level 2 [••]	Level 3 [•••]	Level 4 [••••]	Menu code
APPLIC. Applic. programs	WEIGH			2. 1.
	UNIT Toggle units	DISP.DIG. Display accuracy	o ALL MINUS 1 DIVIS. 1 1 interval	2. 2. 2. 1 2. 2. 2. 2 2. 2. 2. 6
	COUNTING	RESOLUT. Resolution	o DISP.ACC. Display accuracy 10-FOLD 10 times > disp.	2. 3. 1. 1 2. 3. 1. 2
		REF.UPDT. Autom. reference updating	o OFF AUTO	2. 3. 2. 1 2. 3. 2. 2
	PERCENT Weighing in percent	DEC.PLCS Decimal places	NONE No dec. places	2. 4. 1. 1
			o 1 DEC.PL. 1 decimal place	2. 4. 1. 2
			2 DEC.PL. 2 decimal places	2. 4. 1. 3
			3 DEC.PL. 3 decimal places	2. 4. 1. 4
	NET-TOT Net-total	COMP.PRT. Component printout	OFF	2. 5. 1. 1
			o ON	2. 5. 1. 2
	TOTAL Totalizing	COMP.PRT. Component printout	OFF	2. 6. 1. 1
			o ON	2. 6. 1. 2
	ANIMALW. Animal weighing	ACTIVITY. Animal activity	CALM Fluct.: 2% of test obj.)	2. 7. 1. 1
			o ACTIVE (fluct.: 5% of test obj.)	2. 7. 1. 2
			V.ACTIVE(fluct.: 20% of test obj.)	2. 7. 1. 3
		START	MANUAL	2. 7. 2. 1
			o AUTO. Automatic	2. 7. 2. 2
	CALC. Calculation	METHOD (operator)	o MUL. Multiplier	2. 8. 1. 1
			DIV. Divisor	2. 8. 1. 2
		DEC.PLCS Decimal places	NONE No dec. places	2. 8. 2. 1
o 1 DEC.PL. 1 decimal place			2. 8. 2. 2	
2 DEC.PL. 2 decimal places	2. 8. 2. 3			
		3 DEC.PL. 3 decimal places	2. 8. 2. 4	
DENSITY Density determination	DEC.PLCS Decimal places	NONE No dec. places	2. 9. 1. 1	
		o 1 DEC.PL. 1 decimal place	2. 9. 1. 2	
		2 DEC.PL. 2 decimal places	2. 9. 1. 3	
		3 DEC.PL. 3 decimal places	2. 9. 1. 4	

ID Number for ISO/GLP-compliant Data Record

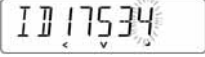

Level 1 [•]	Level 2 [••]	Level 3 [•••]	Menu code
INPUT	ID NO.	ID input; max. 7 characters Permitted characters: 0 to 9; A to Z; dash/hyphen; space	3. 1.

Function of the Keys when Entering ID Numbers

 key: Press and hold to repeat

Display	Key	Display symbol	Function
	First position:		
		>	Go to next position
		V	Select current position
		<<	Exit without saving changes
	Middle positions:		
		V	Select current position
		>	Go to next position
		<	Go to previous position
	Last position:		
	V	Select current position	
	<	Go to previous position	
	↵	Store and exit	

Device Information

Level 1 [•]	Level 2 [••]	Level 3 [•••]	Example	Menu code
INFO Information	VERSION	— Show software version	REL.32.05	4. 1.
	SER. NO.	— Show serial number (To toggle focus between upper and lower display sections, press )	1080 1234	4. 2.
	MODEL	— Show model designation (to change focus from upper to middle to lower display section and back, press )	EJ62025	4. 3.

Display of Menu Items: Text or Codes

LANGUAG.	ENGLISH (factory setting)	5. 1.
	DEUTSCH (German)	5. 2.
	FRANC. (French)	5. 3.
	ITAL. (Italian)	5. 4.
	ESPAÑOL (Spanish)	5. 5.
	РУССКИЙ (Russian)	5. 6.
	POLSKI (Polish)	5. 7.
	CODES Menu shows codes (not texts)	5. 8.

Application Programs

Counting

Display symbol: ☼

Purpose

With the Counting program you can determine the number of parts that each have approximately equal weight. To do this, a known number of parts (the reference sample quantity) is weighed first, and the individual piece weight (reference weight) is calculated from this result.

Thus the number of parts subsequently placed on the balance can be determined from their weight.

Changing the Reference Sample Quantity

Activate function: Press the  key

Select the desired reference sample

quantity (1 to 100):

In increments of 1:

Press the  key briefly

In increments of 10:

Press and hold the  key.

The quantity is stored in battery-backed memory.

Reference Sample Updating

Automatic reference sample updating optimizes the counting accuracy. You can activate or deactivate this function in the menu.

Automatic reference sample updating is performed when the requirements, including the specified stability criterion, have been met.

The abbreviation *OPT*, for “optimizing”, is displayed briefly with the new reference sample quantity.

Preparation

- Select the Counting application in the menu: see “Configuration.”
- Set the following parameters:

APPLIC. Application program

```
COUNT.  
├── RESOLUT. Resolution  
│   ├── o DISP.ACC. Display accuracy  
│   └── 10-FOLD 10-fold higher  
├── REF.UPDT. Autom. ref. sample  
│   └── updating  
│       ├── o OFF Off  
│       └── AUTOM. Automatic
```









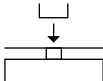

o = Factory setting

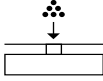
Printout: Counting

nRef	+	10	:	Reference sample quantity
wRef	+	21.14 g	:	Reference weight
Qnt	+	500 pcs	:	Calculated quantity

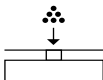
Example: Counting parts of equal weight

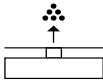
Parameter settings: *APPLIC.: COUNT.* (menu code 2. 3.)

Step	Key (or instruction)	Display/Data output
1. Place empty container on the balance		+ 22.6 g
2. Tare the balance		0.0 g
3. Add reference sample quantity to container (in this example: 20 pcs)		
4. Changing the reference sample quantity:		REF 10 pcs
5. Select reference sample quantity: In increments of 1 (1, 2, 3, etc. to 100) In increments of 10 (10, 20, etc. to 100)	Repeatedly:  Press briefly  press and hold	REF 20 pcs
6. Confirm selected reference sample quantity and start application The current reference weight remains stored until a new reference is set or the power supply is interrupted		+ 20 pcs * nRef 20 pcs wRef 1.07 g
7. Add desired number of pieces		+ 500 pcs
8. If desired, print quantity		Qnt + 500 pcs
9. Toggle display between mean piece weight, weight, quantity	Repeatedly: 	1.07 g Δ * + 535.0 g * + 500 pcs *
10. Unload the balance		- 2 pcs *
11. Repeat as needed, starting from Step 7		
12. Delete reference value		0.0 g

Weighing in Percent

Display symbol: %

Purpose

This application program allows you to obtain weight readouts in percent which are in proportion to a reference weight.

Changing the Reference Percentage

Activate function:

Press the  key

Select the desired reference (1 to 100):

In increments of 1: Press the  key briefly

In increments of 10: Press and hold the  key.

The percentage is stored in battery-backed memory.

Preparation

- Select the Weighing in percent application in the menu: see “Configuration.”
- Set the following parameters:

APPLIC. Application program

└ PERCENT Weighing in percent

└ DEC.PLACES. Decimal places

- └ NONE No decimal places
- └ 0 1 DEC.PL. 1 decimal place
- └ 2 DEC.PL. 2 decimal places
- └ 3 DEC.PL. 3 decimal places

0 = Factory setting









Printout: Weighing in percent

pRef	100	: Reference percentage
Wxx%	111.6 g	: Reference weight net xx% for selected reference percentage
Prc	+ 94.9 %	: Calculated reference percentage

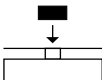
Example: Determining residual weight in percent

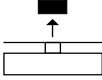
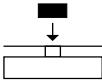
Parameter settings: *APPLIC.: PERCENT* (menu code 2. 4.)

Reference percentage: *REF 100%*

Step	Key (or instruction)	Display/Data output
1. Tare the balance		0.0 g
2. Information: Enter reference percentage (Changing the reference: see the previous page)		REF 100 %
3. Place sample equal to 100% on the balance (in this example: 111.6 g)		
4. Initialize the balance The current reference weight remains stored until a new reference is set or the power supply is interrupted		+ 100.0 % * pRef 100 % Wxx% 111.6 g
5. Remove sample (e.g., for drying)		
6. Place unknown weight on balance (in this example: 105.9 g)		+ 94.9 % *
7. If desired, print percentage		Prc + 94.9 %
8. Toggle display between weight and percentage	Repeatedly: 	+ 105.9 g * + 94.9 % *
9. Clear display of residual weight and reference percentage		+ 105.9 g
10. If desired, print net residual weight		N + 105.9 g

Calculation

Display symbol: C

Purpose

With this application program you can calculate weight value using a multiplier or divisor. This can be used, for example, to determine the weight per unit area, or “gsm” weight (grams per square meter), of paper.

Setting the Factor or Divisor

Activate function:

Press the  key

Select a number of up to 7 digits and, if needed, one decimal point (0.000001 to 9999999):

In increments of 1: Press the  key briefly

To increase the value without pressing repeatedly:

Press and hold the  key.

The selected operator is stored in battery-backed memory.

Preparation

- Select the Calculation application in the menu: see “Configuration.”
- Set the following parameters:

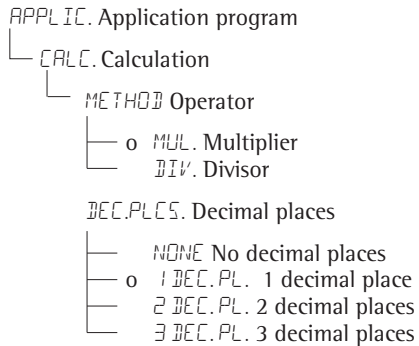

o = Factory setting

Printout: Calculation











MUL	+	1.2634	:	Multiplier
DIV	+	0.6237	:	Divisor
RES	+	79.7	o	Result

Example:

Calculating the weight per unit area of paper: An A4 sheet of paper is used in this example, with surface dimensions of $0.210\text{ m} \times 0.297\text{ m} = 0.06237\text{ m}^2$. To determine the weight per unit area, the total weight is divided by the surface.

Parameter settings:

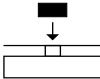
APPLIC.: CALC.: METHOD: DIV. (menu code 2. 8. 1. 2)

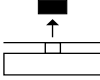
Step	Key (or instruction)	Display/Data output
1. Tare the balance		0.00 g
2. Activate divisor input		-----0.
3. Set the divisor (in this example:0.06237): Position the decimal point, Enter numerals	 , 5x  , 2x  , Repeatedly or press and hold;  ,  , etc.	...00000 ...06000 ...06237
4. Store the divisor and initialize the balance The current divisor remains stored in battery-backed memory until the setting is changed		+ 0.0 ° Div 0.6237
5. Weight per unit area: Place an A4 sheet of paper on the balance		+ 79.7 ° *
6. If desired, print result		Res + 79.7 °
7. Toggle display between weight and calculated value	Repeatedly: 	+ 4.97 g * + 79.7 ° *
8. Unload the balance		+ 0.0 ° *
9. Repeat as needed, starting from Step 5		

Animal Weighing/Averaging

Display symbol: 

Purpose

Use this program to determine the weights of unstable samples (e.g., live animals) or to determine weights under unstable ambient conditions. With this program, the balance calculates the weight as the average of a defined number of individual weighing operations (also referred to as “subweighing operations”).

Changing the Number of Subweighing Operations

Activate function:

Press the  key

Select the desired number of measurement (1 to 100):

In increments of 1: Press the  key briefly

In increments of 10: Press and hold the  key.

The selected number of measurements is stored in battery-backed memory.

Preparation

- Select the Animal weighing application in the menu:
see “Configuration.”

- Set the following parameters:

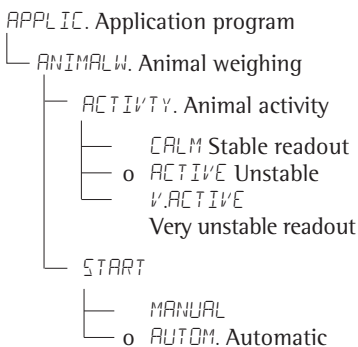

o = Factory setting

Printout: Animal weighing

mDef	20	: Number of sub-
		weighing operations
x-Net +	410.1 g	: Calculated average

Example: Determining animal weight with automatic start and 20 subweighing operations (measurements)

Parameter settings: *APPLIC.: ANIMALW.* (menu code 2. 7.)

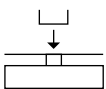
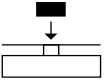
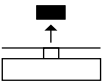
Step	Key (or instruction)	Display/Data output
1. Place animal weighing bowl on the balance		22.6 g
2. Tare the balance	(Tare)	0.0 g
3. Change the number of subweighing operations:	(Select Menu)	REF 30
4. Set number of measurements: In increments of 1 (1, 2, 3, etc. to 100) In increments of 10 (10, 20, etc. to 100)	Repeatedly: Press briefly (Select Menu) press and hold	REF 20
5. Confirm number of measurements and start automatic animal weighing The number of measurements remains stored in battery-backed memory until the setting is changed	(Enter)	+ 0.0 g *
6. Place first animal in bowl. The balance delays the start of measurements until the difference between 2 measurements meets the criterion		888 20 19 ... 1
7. Read off the result The result is displayed with the “*” symbol (= calculated value) and remains displayed until the sample (animal) is removed from the load plate (bowl)		+ 410.1 g Δ* mDef 20 x-Net + 410.1 g
8. Unload the balance		+ 0.0 g *
9. Weigh next animal (if des.)		

Next weighing series begins automatically



Net-total Formulation

Display symbol: 

Purpose

With this application program you can weigh in different components up to a defined total. You can print out both the total weight and the individual weights of the components.

Features

- Weigh up to 99 components from “0” to a defined total component weight.
- Store component weights (“Store xx comp.”), with
 - display zeroed automatically after value is stored, and
 - automatic printout
- Clear component memory following cancellation of the weighing sequence (by pressing ) and printout of the total weight.
- Toggling between component weight and total weight by pressing and holding  (< 2 sec).
- Printout of the total of the individual component weights (T-Comp)

Preparation

- Select the Net-total application in the menu:
see “Configuration.”
- Set the following parameters:

```
APPLIC. Application program
├── NET-TOTL. Net-total formulation
│   └── COMP.PRT. Printout of components
│       ├── OFF
│       └── o ON
```

o = Factory setting







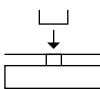

Printout: Net-total formulation

Comp 2+	278.1 g	: Second component
T-Comp+	2117.5 g	: Sum of components

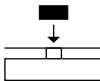
Example: Counting parts into a container

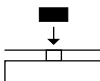
Parameter settings:

APPLIC.: NET-TOT (menu code 2. 5.)

Step	Key (or instruction)	Display/Data output
1. Place empty container on the balance.		65.0 g
2. Tare the balance		0.0 g
3. Add first component		+ 120.5 g
4. Store component data		+ 0.0 g * NET Comp 1+ 120.5 g
5. Add next component		+ 70.5 g * NET
6. Store component data		+ 0.0 g * NET Comp 2+ 70.5 g
7. Weigh in further components as desired	Repeat steps 5 and 6	
8. Fill to desired final value view the current total weight value:		+ 191.0 g *
9. Print total weight and clear the component memory		+ 2117.5 g T-Comp+ 2117.5 g



Totalizing

Display symbol: 

Purpose

With this application program you can add values from successive, mutually independent weight values to a total that exceeds the capacity of the balance.

Features

- Totalizing memory for up to 99 values
- Store component weights ("Store xx comp."), with automatic printout
- Toggle display between the current individual weight value and the value in totalizing memory by pressing 
- Printout of the total of the individual component weights (**S-Comp**)
- To close the application program and print the total weight: press 

Preparation

- Select the Totalizing application in the menu:
see "Configuration."
- Set the following parameters:

```
APPLIC. Application program
├── TOTAL Totalizing
│   ├── COMP.PRT. Printout of components
│       ├── OFF
│       └── 0 ON
```

0 = Factory setting







Printout: Totalizing

Comp 2+	278.1 g	: Second component
S-Comp+	2117.5 g	: Totalizing memory

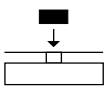
Example: Totalizing weight values

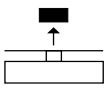
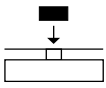
Parameter settings:

APPLIC.: TOTAL: COMP.PRT: ON (menu code 2. 6. 1. 2)

Step	Key (or instruction)	Display/Data output
1. Tare the balance		0.0 g
2. Place sample balance (in this example: 380 g)		+ 380.0 g
3. Store value in memory		+ 380.0 g * Comp 1+ 380.0 g
4. Remove sample		+ 0.0 g *
5. Place the next sample on the balance (in this example, 575 g)		+ 575.0 g *
6. Store value in memory		+ 955.0 g * + 575.0 g * Comp 2+ 575.0 g
7. View the value in totalizing memory		+ 955.0 g Δ*
8. Weigh in further components as desired	Repeat steps 5 and 6	
9. Print total weight and clear the totalizing memory		0.0 g S-Comp+ 2117.5 g

Mass Unit Conversion

Purpose











With this application program you can change the weight value displayed from the basic weight unit to any of 4 application weight units (see table on next page).

Features

- Set the basic unit and display accuracy in the Setup menu: see “Configuration.”
- Set the application weight units and display accuracies in the Application menu.
- These settings are stored in battery-backed memory.
- The basic unit is active when the balance is powered up.

Example: Change display from the basic unit (in this example, grams [g]) to pounds [lb] and then to Troy ounces [ozt].

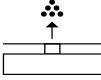
Set the following parameters: *APPLIC.: UNIT* (code 2. 2.)

Step	Key (or instruction)	Display/Data output
Preparation:		
1. Begin selection of an application weight unit		NONE ° [•]
2. Select an application unit; in this example, pounds (see table on next page)	Repeatedly: 	POUNDS
3. Confirm the weight unit (pounds)		POUNDS °
4. Select the next application weight unit; in this example: Troy ounces (see table on next page)	 , Repeatedly: 	NONE ° [••] TROY OZ.
5. Confirm weight unit (Troy ounces)		TROY OZ. °
6. Select other application units if desired (max. 4 total) (otherwise, confirm NONE by pressing )		[•••]
7. Store selection		0.00 g
Conversion:		
8. Place sample on balance		+ 100.00 g
9. Toggle unit for weight value	Repeatedly: 	+ 0.22046 lb + 3.5275 ozt

The following weight units are available in your balance:

Menu item	Unit	Conversion factor	Display symbol
1) <i>USERDEF.</i> ¹⁾	Grams	1,0000000000	o
2) <i>GRAMS</i> (Factory setting)	Grams	1.0000000000	g
3) <i>KILOGR.</i>	Kilograms	0.0010000000	kg
4) <i>CARATS</i>	Carats	5.0000000000	o
5) <i>POUNDS</i>	Pounds	0.00220462260	lb
6) <i>OUNCES</i>	Ounces	0.03527396200	oz
7) <i>TROY OZ.</i>	Troy ounces	0.03215074700	ozt
8) <i>HKTAEI.</i>	Hong Kong tael	0.02671725000	tl
9) <i>SNG.TAEI.</i>	Singapore tael	0.02645544638	tl
10) <i>TWN.TAEI.</i>	Taiwanese tael	0.02666666000	tl
11) <i>GRAINS</i>	Grains	15.4323583500	GN
12) <i>PENY.WT.</i>	Pennyweights	0.64301493100	dwt
13) <i>MILLIGR.</i>	Milligrams	1000.00000000	mg
14) <i>PT.P.LB.</i>	Parts per pound	1.12876677120	o
15) <i>CHN.TAEI.</i>	Chinese tael	0.02645547175	tl
16) <i>MOMMES</i>	mommes	0.26670000000	m
17) <i>AUSTRICT.</i>	Austrian carats	5.00000000000	Kt
18) <i>TOLA</i>	Tola	0.08573333810	o
19) <i>BAHT</i>	Baht	0.06578947436	b
20) <i>MESGHAL</i>	Mesghal	0.21700000000	o
21) <i>TONS</i>	Tons	0.00000100000	t
22) <i>LB/OZ²⁾</i>	Pounds : ounces	0.03527396200	lb oz
23) <i>NEWTON</i>	Newton	0.00980665000	N

¹⁾ = User-defined weight unit; can be loaded in the balance over an optional RS-232 or USB interface using a computer program.

²⁾ = The format for display of pounds/ounces cannot be changed: xx:yy.yy x=lb, y=oz

Density Determination

Display symbol: $\bar{\Delta}$

Purpose

This application program lets you determine the density of solid substances using the buoyancy method.

Features

Press  to enter the density of the buoyancy liquid* at the corresponding temperature. See the next page for a table of density values for water. The factory setting is 1 g/cm².

The following formula is applied:

Density of sample =

$$\frac{\text{Weight in air}}{(\text{Weight in air} - \text{weight in water})} \cdot \text{density of liquid}$$

When you start the density determination routine, the density of the liquid is displayed briefly. Positive and negative values can be stored for weight in air and weight in water. The weight in water must be less than the weight in air; otherwise, an error message is displayed.

You can have results displayed with one, decimal places, or no decimal places: see “Configuration.” Note: the sample holder and suspension wire used in the example below are not included with the balance.

Preparation

- Select the Density Determination application in the menu: see “Configuration.”
- Set the following parameters:

APPLIC. Application program

```

  DENSITY Density determination
  └─ DEC.PLCS. Decimal places
      └─ NONE No decimal places
      └─ o 1 DEC.PL. 1 decimal place
      └─ 2 DEC.PL. 2 decimal places*
      └─ 3 DEC.PL. 3 decimal places*
```

Note:

When three decimal places are shown, the third decimal place might be erroneous; for example, if corrections for air density and the particular density determination kit used are not considered.

- * = With software versions 32.05 and later. For details on displaying the software version number, see page 24.
o = Factory setting

Printout for Density Determination

RhoFL	0.99823	o	: Density of liquid (g/cm ³)
Wa	+	20.0	g : Weight in air
WfL	+	15.0	g : Weight in liquid
Rho		4.0	o : Result: density of the sample







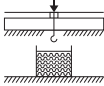

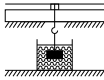



Table:

Density of H₂O at Temperature T (in °C)

T/°C	0.0	0.1	0.2	0.3	0.4	0.5	0.6	0.7	0.8	0.9
10.	0.99973	0.99972	0.99971	0.99970	0.99969	0.99968	0.99967	0.99966	0.99965	0.99964
11.	0.99963	0.99962	0.99961	0.99960	0.99959	0.99958	0.99957	0.99956	0.99955	0.99954
12.	0.99953	0.99951	0.99950	0.99949	0.99948	0.99947	0.99946	0.99944	0.99943	0.99942
13.	0.99941	0.99939	0.99938	0.99937	0.99935	0.99934	0.99933	0.99931	0.99930	0.99929
14.	0.99927	0.99926	0.99924	0.99923	0.99922	0.99920	0.99919	0.99917	0.99916	0.99914
15.	0.99913	0.99911	0.99910	0.99908	0.99907	0.99905	0.99904	0.99902	0.99900	0.99899
16.	0.99897	0.99896	0.99894	0.99892	0.99891	0.99889	0.99887	0.99885	0.99884	0.99882
17.	0.99880	0.99879	0.99877	0.99875	0.99873	0.99871	0.99870	0.99868	0.99866	0.99864
18.	0.99862	0.99860	0.99859	0.99857	0.99855	0.99853	0.99851	0.99849	0.99847	0.99845
19.	0.99843	0.99841	0.99839	0.99837	0.99835	0.99833	0.99831	0.99829	0.99827	0.99825
20.	0.99823	0.99821	0.99819	0.99817	0.99815	0.99813	0.99811	0.99808	0.99806	0.99804
21.	0.99802	0.99800	0.99798	0.99795	0.99793	0.99791	0.99789	0.99786	0.99784	0.99782
22.	0.99780	0.99777	0.99775	0.99773	0.99771	0.99768	0.99766	0.99764	0.99761	0.99759
23.	0.99756	0.99754	0.99752	0.99749	0.99747	0.99744	0.99742	0.99740	0.99737	0.99735
24.	0.99732	0.99730	0.99727	0.99725	0.99722	0.99720	0.99717	0.99715	0.99712	0.99710
25.	0.99707	0.99704	0.99702	0.99699	0.99697	0.99694	0.99691	0.99689	0.99686	0.99684
26.	0.99681	0.99678	0.99676	0.99673	0.99670	0.99668	0.99665	0.99662	0.99659	0.99657
27.	0.99654	0.99651	0.99648	0.99646	0.99643	0.99640	0.99637	0.99634	0.99632	0.99629
28.	0.99626	0.99623	0.99620	0.99617	0.99614	0.99612	0.99609	0.99606	0.99603	0.99600
29.	0.99597	0.99594	0.99591	0.99588	0.99585	0.99582	0.99579	0.99576	0.99573	0.99570
30.	0.99567	0.99564	0.99561	0.99558	0.99555	0.99552	0.99549	0.99546	0.99543	0.99540

Example: Determining the density of a solid using water as the buoyancy liquid.
 The density of water at 20°C is 0.99823 g/cm³.

Parameter settings: *APPLIC.: DENSITY; DEC.PLCS 1 DEC.PL.* (menu code 2. 9. 1. 2)

Step	Key (or instruction)	Display/Data output
1. Attach sample holder to suspension wire		
2. Tare the balance		0.0 g
3. Edit the stored density value		_ 1.00000
4. Enter the density of the liquid (in this example: 0.99823)	 repeatedly, briefly or press and hold;  , etc.	_ 0.99823
5. Save density value and start application The density value is stored in battery- backed memory		
6. Confirm "AIR" display		AIR ?
7. Determine the weight of the sample in air: Place sample on the balance		+ 20.0 g ?*
8. Store value for weight in air		
9. Remove sample from the balance		WATER ?
10. Determine weight in liquid: place sample in holder		
11. Confirm "WATER" display		0.0 g ?*
12. Immerse sample in liquid		+ 15.0 g ?*
13. Store value for weight in liquid, view result, and print		+ 4.0 ⁰ ?* RhoFL 0.6237 o Wa + 20.0 g WfL + 15.0 g
		Rho 4.0 o
14. Delete result		
15. Repeat as desired, starting from Step 5.		

ISO/GLP-compliant Printout/Record

Features

You can have device information, ID texts and date and time printed before (GLP header) and after (GLP footer) the values of a weighing series. These parameters include:

- GLP header:
- Date
 - Time at beginning of measurement
 - Balance manufacturer
 - Balance model
 - Balance serial number
 - Software version number
 - Identification number of the current sampling operation

GLP footer:

- Date
- Time at end of measurement
- Field for operator signature

△ Operating the Balance with a Verifiable ISO/GLP Printer:

- Connect a Sartorius data printer designed for ISO/GLP documentation (e.g., the YDP20-OCE printer) to the balance.

Configuration

- Setting menu codes for the printout (see “Configuration”):
 - ISO/GLP-compliant printout or record only for calibration/adjustment:
SETUP: PRNT.OUT: GLP: CAL.-ADJ.
(menu code 1. 6. 7. 2) or
ISO/GLP-compliant printout or record always on: *SETUP: PRNT.OUT: GLP: ALWAYS ON* (code 1. 6. 7. 3)
 - Line format for printout: include data ID codes (22 characters; factory setting):
SETUP: PRNT.OUT: FORMAT: 22 CHAR.

(menu code 1. 6. 6. 2)

- Formats for time:
SETUP: PRNT.OUT: TIME: 24H
(menu code 1. 6. 8. 1) or
SETUP: PRNT.OUT: TIME: 12H
(menu code 1. 6. 8. 2)
- Formats for date:
SETUP: PRNT.OUT: DATE: DD.MMM.YY
(menu code 1. 6. 9. 1) or
SETUP: PRNT.OUT: DATE: MMM.DD.YY
(menu code 1. 6. 9. 2)

- △ No ISO/GLP-compliant record is output if any of the following settings are configured:

SETUP: PRNT.OUT PRINT: AUT.W/O or
AUT.WITH (menu code 1. 6. 1. 3, 1. 6. 1. 4,) or *FORMAT: 16 CHAR.* (menu code 1. 6. 6. 1)



Function Keys

Transfer header and first measured value: press 

- > The header is included with the first printout/data record.

To output header and reference data automatically when an application program is active: press 

Exit the application:

- 1) To send the GLP footer:
press 
- 2) Quit application program:
press  again

The ISO/GLP-compliant printout can contain the following lines:

-----		Dotted line
17-Jun-2010	10:15	Date/time (beginning of measurement)
SARTORIUS		Balance manufacturer
Mod.	AX6202	Model
Ser. no.	10105355	Balance serial number
Ver. no.	00-32-07	Software version
ID	2690 923	ID.
-----		Dotted line
L ID		Measurement series no.
nRef	10 pcs	Counting: reference sample quantity
wRef	21.14 g	Counting: reference weight
Qnt +	567 pcs	Counting result
-----		Dotted line
17-Aug-2010	10:20	Date/time (end of measurement)
Name:		Field for operator signature
-----		Blank line
-----		Dotted line

ISO/GLP-compliant printout for external calibration/adjustment:

-----		Dotted line
17-Jun-2010	10:30	Date/time (beginning of measurement)
SARTORIUS		Balance manufacturer
Mod.	AX6202	Model
Ser. no.	10105352	Balance serial number
Ver. no.	00-32-07	Software version
ID	2690 923	ID.
-----		Dotted line
Cal. Ext. Test		Calibration/adjustment mode
Set +	5000.00 g	Calibration weight
Diff. +	0.02 g	Difference determined in calibration
Cal. Ext. Complete		Confirmation of completed calibration procedure
Diff.	0.00 g	Difference from target following adjustment
-----		Dotted line
17-Aug-2010	10:32	Date/time (end of measurement)
Name:		Field for operator signature
-----		Blank line
-----		Dotted line

Data Interface

Purpose

Your balance comes equipped with an interface port for connection to a computer or other peripheral device. You can use an on-line computer to change, start and/or monitor the functions of the balance and the application programs.

Female interface connector

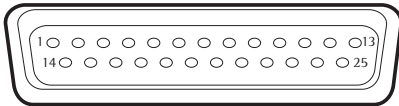

Pin Assignment Chart, 25-pin female interface connector, RS-232:

- Pin 1: Shield
- Pin 2: Data output (TxD)
- Pin 3: Data input (RxD)
- Pin 4: Internal ground (GND)
- Pin 5: Clear to Send (CTS)
- Pin 6: Not connected
- Pin 7: Internal ground (GND)
- Pin 8: Internal ground (GND)
- Pin 9: Not connected
- Pin 10: Not connected
- Pin 11: +12 V
(operating voltage for Sartorius printer)
- Pin 12: Reset _ Out *)
- Pin 13: +5 V output
- Pin 14: Internal ground (GND)
- Pin 15: Universal remote switch
- Pin 16: Not connected
- Pin 17: Not connected
- Pin 18: Not connected
- Pin 19: Not connected
- Pin 20: Data Terminal Ready (DTR)
- Pin 21: Not connected
- Pin 22: Not connected
- Pin 23: Not connected
- Pin 24: Not connected
- Pin 25: +5 V output

Preparation

You can set these parameters for other devices in the Setup menu (see the chapter entitled “Configuring the Balance”). You will also find a detailed description of the available data interface commands in the file “Data Interface Descriptions for AX, BSA, ED, GK and GW Models”, which you can download from the Sartorius website (www.sartorius.com “Download Center”).

The many and versatile properties of these balances can be fully utilized for printing out records of the results when you connect your balance to a Sartorius data printer. The recording capability for printouts makes it easy for you to work in compliance with ISO/GLP.

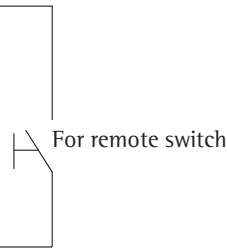

*) = Hardware restart

Troubleshooting Guide

Error codes are shown on the main display for approx. 2 seconds. The program then returns automatically to the previous mode.

Display	Cause	Solution
No segments appear on the display	No AC power is available The power supply is not plugged in	Check the AC power supply Plug in the power supply
<i>HIGH</i>	The load exceeds the balance capacity	Unload the balance
<i>LOW</i> or <i>ERR 54</i>	Something is touching the weighing pan	Move the object that is touching the weighing pan
<i>APP.ERR.</i>	Cannot store data: Load on weighing pan too light or no sample on pan while application is active	Increase load
<i>DIS.ERR.</i>	Data output not compatible with output format	Change the configuration in the operating menu
<i>PRT.ERR.</i>	Interface port for printer output is blocked	Reset the menu factory settings, or Contact your local Sartorius Service Center
<i>ERR 02</i>	Calibration parameter not met; e.g.: – balance not tared – load on weighing pan	Calibrate only when zero is displayed – Press Tare to tare the balance – Unload the balance
<i>ERR 10</i>	The Tare key is blocked when there is data in the second tare memory (net-total); only 1 tare function can be used at a time	Press CF to clear the tare memory and release the tare key
<i>ERR 11</i>	Tare memory not allowed	Press Tare
The weight readout changes constantly	Unstable ambient conditions (excessive vibration or draft) at the place of installation A foreign object is caught between weighing pan, pan support and balance housing	Set up the balance in another area Remove the foreign object
The weight readout is obviously wrong	The balance was not calibrated/adjusted Balance not tared before weighing	Calibrate/adjust the balance Tare or zero the balance before weighing

If any other errors occur, contact your local Sartorius Service Center.

Contact information: Please point your Internet browser to: <http://www.sartorius.com>

Care and Maintenance

Service

On request, Sartorius can offer you an individual service contract.

Repairs

Repair work must be performed by trained service technicians. Any attempt by untrained persons to perform repairs may result in considerable hazards for the user.

Cleaning

- Unplug the AC adapter from the wall outlet (mains supply). If you have an interface cable connected to the balance port, unplug it from the port.
- △ Make sure that no liquid enters the balance housing.
- △ Do not use aggressive cleaning agents (solvents or similar agents).
- After cleaning, wipe down the balance with a soft, dry cloth.

On analytical balances remove and clean the weighing pan as follows:

- Reach beneath the shield disk and lift it carefully, together with the pan support, to avoid damaging the weighing system.

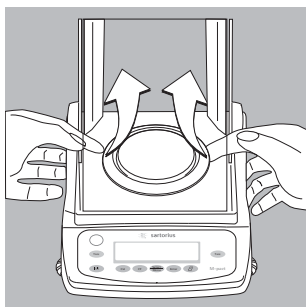

Cleaning Stainless Steel Surfaces

Clean all stainless steel parts regularly. Remove the stainless steel weighing pan and thoroughly clean it separately. Use a damp cloth or sponge to clean stainless steel parts on the balance. You can use any household cleaning agent that is suitable for use on stainless steel. Clean stainless steel surfaces only by wiping them down. Then rinse the equipment thoroughly, making sure to remove all residues. Afterwards, allow the equipment to dry. If desired, you can apply oil to the cleaned surfaces as additional protection.

Recycling

Safety Inspection

If there is any indication that safe operation of the balance is no longer warranted:

- Turn off the power and disconnect the equipment from AC power immediately.
- > Lock the equipment in a secure place to ensure that it cannot be used for the time being.

Notify your nearest Sartorius Service Center. Repair work must be performed by trained service technicians.

We recommend having the power supply inspected by a certified electrician at regular intervals, according to the following checklist:

- Insulating resistance: > 7 megaohms measured with a constant voltage of at least 500 volts at a 500 K-ohm load
- Leakage current: < 0.05 mA measured with a properly calibrated multimeter

Information and Instructions on Disposal and Repairs

Packaging that is no longer required must be disposed of at the local waste disposal facility. The packaging is made of environmentally friendly materials that can be used as secondary raw materials.



The equipment, including accessories and batteries, does not belong in your regular household waste.

The EU legislation requires its Member States to collect electrical and electronic equipment and disposed of it separately from other unsorted municipal waste with the aim of recycling it.

In Germany and many other countries, Sartorius AG takes care of the return and legally compliant disposal of its electrical and electronic equipment on its own. These products may not be placed with the household waste or brought to collection centers run by local public disposal operations – not even by small commercial operators.

For disposal in Germany and in the other Member States of the European Economic Area (EEA), please contact our service technicians on location or our Service Center in Goettingen, Germany:

Sartorius AG
Service Center
Weender Landstrasse 94-108
37075 Goettingen, Germany

In countries that are not members of the European Economic Area (EEA) or where no Sartorius affiliates, subsidiaries, dealers or distributors are located, please contact your local authorities or a commercial disposal operator.

Prior to disposal and/or scrapping of the equipment, any batteries should be removed and disposed of in local collection boxes.

Sartorius AG, its affiliates, subsidiaries, dealers and distributors will not take back equipment contaminated with hazardous materials (ABC contamination) – either for repair or disposal. Please refer to the accompanying leaflet/manual or visit our Internet website (www.sartorius.com) for comprehensive information that includes our service addresses to contact if you plan to send your equipment in for repairs or proper disposal.

Overview

Specifications

Specifications

AC power source/power requirements, voltage, frequency		AC adapter 230 V or 115 25 V, +15% to – 20%, 48–60 Hz
Power consumption	VA	maximum 16; typical 8 (STNG6)
Approx. hours of operation with the YRB05Z rechargeable battery pack (backlighting on)	h	35

Ambient Conditions

The specifications given here are ensured under the following ambient conditions:

Operating temperature range	+10 to +30°C (273 to 303 K, 50 to 86°F)
Allowable ambient operating temperature	+5 to +40°C (41 to 104°F)

Proper functioning is ensured within an ambient operating temperature range of 5 to 40°C (41 to 104°F).

Electromagnetic compatibility (EMC)	EN61326-1
Emission	Class B
Immunity	industrial areas

Specifications for Individual Models

Model		AX224	AX124
Weighing capacity		220 g	120 g
Readability		0.0001 g	0.0001 g
Tare range (subtractive)		220 g	120 g
Repeatability (std. deviation)	≤±	0.0002 g	0.0002 g
Linearity	≤±	0.0003 g	0.0003 g
Response time (average)	s	3	3
Sensitivity drift within +10 to +30°C	≤±/K	$2 \cdot 10^{-6}$	
Adaptation to ambient conditions		By selection of 1 of 4 optimized filter levels; display update: 0.1–0.4 s (depends on filter level selected)	
External calibration weight (of at least accuracy class...)	g	200 (E2)	100 (E2)
Net weight, approx.:	kg	4.4	
Weighing pan size	mm	90 Ø	
Whg. chamber height	mm	230	
Dimensions (W × D × H)	mm	230 × 310 × 330	

Model		AX623	AX423
Weighing capacity		620 g	420 g
Readability		0.001 g	0.001 g
Tare range (subtractive)		620 g	420 g
Repeatability (std. deviation)	≤±	0.002 g	0.002 g
Linearity	≤±	0.004 g	0.004 g
Response time (average)	s	1.5	1.5
Sensitivity drift within +10 to +30°C	≤±/K	$2 \cdot 10^{-6}$	$2 \cdot 10^{-6}$
Adaptation to ambient conditions		By selection of 1 of 4 optimized filter levels; display update: 0.05–0.4 s (depends on filter level selected)	
External calibration weight (of at least accuracy class...)	g	500 (E2)	200 (E2)
Net weight, approx.:	kg	4.5	
Weighing pan size	mm	115 Ø	
Dimensions (W × D × H)	mm	230 × 310 × 136	

Model		AX6202	AX4202	AX2202	AX822
Weighing capacity	g	6200	4200	2200	820
Readability	g	0.01	0.01	0.01	0.01
Tare range (subtractive)	g	6200	4200	2200	820
Repeatability (std. deviation)	≤±g	0.02	0.02	0.02	0.02
Linearity	≤±g	0.04	0.04	0.04	0.04
Stabilization time (typical)	s	1.5	1.5	1.5	1.5
Sensitivity drift within +10 to +30°C	≤±/K	2 · 10 ⁻⁶	2 · 10 ⁻⁶	2 · 10 ⁻⁶	5 · 10 ⁻⁶
Adaptation to ambient conditions		By selection of 1 of 4 optimized filter levels; display update: 0.05–0.4 s (depends on filter level selected)			
External calibration weight (of at least accuracy class...)	g	5000 (E2)	2000 (E2)	2000 (F1)	500 (F2)
Net weight, approx.:	kg	3.1	3.1	3.1	2
Weighing pan size	mm	180 × 180	180 × 180	180 × 180	150 ∅
Dimensions (W × D × H)	mm	230 × 310 × 91			230×310×87

Accessories

External calibration weights:

For model	Accuracy class	Weight in grams	Order no.
AX224	E2	200	YCW5228-00
AX124	E2	100	YCW5128-00
AX423	E2	200	YCW5228-00
AX623	E2	500	YCW5528-00
AX4202	E2	2000	YCW6228-00
AX6202	E2	5000	YCW6528-00
AX2202	F1	2000	YCW6238-00
AX822	F2	500	YCW5548-00

Product

Data printer

with date, time, statistics evaluation, transaction counter functions and LCD

Order No.

YDP20-OCE

Product

Density determination kit

– for AX224, AX124

YDK01B

Standard

Operating Procedure

optimum use of your balance in quality-management systems

YSL07E

Remote display, reflective (for connection to data interface port)

YRD03Z

External rechargeable battery pack

With battery-level indicator (LED); can be recharged using the AC adapter (charge time for completely discharged battery pack: 15 hours); see “Specifications” for hours of operation.

To recharge the battery pack: Unplug the AC adapter from the balance and plug it into the battery pack

YRB05Z

Data cable

– for connecting a computer with a USB port

YCC01-USBM2

– for computer connection, 25-pin

7357312

– for computer connection, 9-pin

7357314

Adapter cable

from D-Sub 25-pin male connector to D-Sub 9-contact female connector; length: 0.25 m

6965619

SartoCollect

data transfer software for direct transmission of weight values to another program (e.g., MS Excel)

YSC02

Universal remote control switch

for remote control of the following functions:

, ,  or a function key

(see “Configuration” for details):

Foot switch with T-connector

Hand switch with T-connector

Order No.

YFS01

YHS02

T-connector

Note:

The T-connector is not intended for connecting multiple intelligent peripheral devices, such as PCs or YDP03-OCE printers.

YTC01

Ionizing blower for eliminating static electricity

- 220 V
- 110 V

YIB01-ODR

YIB01-OUR

Stat-Pen anti-static device for eliminating electrostatic charges on samples and containers (100 V to 230 V, 50/60 Hz)

YSTP01

In-use dust cover

- for models with a rectangular weighing pan
- for models with a round weighing pan (150 mm diameter)

YDC05-A

YDC06-A



sartorius
mechatronics

CE EG-Konformitätserklärung EC Declaration of Conformity

Sartorius AG
Weender Landstr. 94 – 108
37075 Göttingen, Germany

erklärt, dass das Betriebsmittel
declares that the equipment

Gerät: Elektronische Analysenwaage / Präzisionswaage
Apparatus: Electronic Analytical Balance / Precision Balance

Baureihe / Batch: AX...

Typbezeichnung: Siehe Anhang 1
Type: See Annex 1

mit den grundlegenden Anforderungen der folgenden Europäischen Richtlinien übereinstimmt:
complies with the basic requirements of the following European Directives:

Richtlinie 2004/108/EG Elektromagnetische Verträglichkeit
Directive 2004/108/EC Electromagnetic compatibility

Richtlinie 2006/95/EG Elektrische Betriebsmittel zur Verwendung innerhalb bestimmter Spannungsgrenzen
Directive 2006/95/EC Electrical equipment designed for use within certain voltage limits

Das Gerät erfüllt die anwendbaren Anforderungen der in Anhang 2 aufgeführten harmonisierten Europäischen Normen.

The apparatus meets the applicable requirements of the harmonized European Standards listed in Annex 2.

Jahr der Anbringung des CE-Zeichens: 10
Year of attachment of CE mark:

Sartorius AG
Göttingen, 2010-07-30

Dr. Reinhard Baumfalk
Leitung Entwicklung
Mechatronik
*Vice President, R&D
Mechatronics*

Dr. Dieter Klausgrete
Leitung International Certification Management
Mechatronik
*Head of International Certification Management
Mechatronics*



EG-Konformitätserklärung *EC Declaration of Conformity*

Anhang 1 | *Annex 1*

Typ / type:

AX124
AX224
AX423
AX623
AX822
AX2202
AX4202
AX6202

.....

Anhang 2 | *Annex 2*

Liste der angewendeten harmonisierten Europäischen Normen
List of the applied harmonized European Standards

1. Richtlinie 2004/108/EG | *Directive 2004/108/EC*

EN 61326-1:2006 Elektrische Mess-, Steuer-, Regel- und Laborgeräte - EMV- Anforderungen - Teil 1: Allgemeine Anforderungen (IEC 61326-1:2005)
Electrical equipment for measurement, control and laboratory use - EMC requirements - Part 1: General requirements (IEC 61326-1:2005)

2. Richtlinie 2006/95/EG | *Directive 2006/95/EC*

EN 61010-1:2001 Sicherheitsbestimmungen für elektrische Mess-, Steuer-, Regel- und Laborgeräte - Teil 1: Allgemeine Anforderungen (IEC 61010-1:2001)
Safety requirements for electrical equipment for measurement, control, and laboratory use - Part 1: General requirements (IEC 61010-1:2001)

.....

Address label / Dealer's stamp

Sartorius AG
Weender Landstrasse 94–108
37075 Goettingen, Germany

Phone +49.551.308.0
Fax +49.551.308.32 89
www.sartorius-mechatronics.com

Copyright by Sartorius AG, Goettingen, Germany.
All rights reserved. No part of this publication may
be reprinted or translated in any form or by any means
without the prior written permission of Sartorius AG.
The status of the information, specifications and illustrations
in this manual is indicated by the date given below.
Sartorius AG reserves the right to make changes to the
technology, features, specifications and design of the
equipment without notice.

Status:
September 2010, Sartorius AG,
Goettingen, Germany