

Thermo Scientific

MicroClick 30x2 Rotor

For use with Thermo Scientific Heraeus Megafuge 8,
Sorvall ST 8 and SL 8 Centrifuges

Instruction Manual

50139049-a

February 2013

Visit us online to register your warranty.
www.thermoscientific.com/labwarranty

© 2013 Thermo Fisher Scientific Inc. All rights reserved.

HERAEUS is a registered trademark of Heraeus Holding GmbH licensed to Thermo Fisher Scientific. Delrin, TEFLON, and Viton are registered trademarks of DuPont. Noryl is a registered trademark of SABIC. POLYCLEAR is a registered trademark of Hongye CO., Ltd. Hypaque is a registered trademark of Amersham Health As. RULON A and Tygon are registered trademarks of Saint-Gobain Performance Plastics. Alconox is a registered trademark of Alconox. Ficoll is a registered trademark of GE Healthcare. Haemo-Sol is a registered trademark of Haemo-Sol. Triton X-100 is a registered trademark of Sigma-Aldrich Co. LLC

All other trademarks are the property of Thermo Fisher Scientific Inc. and its subsidiaries.

Thermo Fisher Scientific Inc. provides this document to its customers with a product purchase to use in the product operation. This document is copyright protected and any reproduction of the whole or any part of this document is strictly prohibited, except with the written authorization of Thermo Fisher Scientific Inc.

Manufacturer:
Thermo Electron LED GmbH
Robert-Bosch-Straße 1
D - 63505 Langenselbold
Germany

The contents of this document are subject to change without notice. All technical information in this document is for reference purposes only. System configurations and specifications in this document supersede all previous information received by the purchaser.

Thermo Fisher Scientific Inc. makes no representations that this document is complete, accurate or errorfree and assumes no responsibility and will not be liable for any errors, omissions, damage or loss that might result from any use of this document, even if the information in the document is followed properly.

This document is not part of any sales contract between Thermo Fisher Scientific Inc. and a purchaser. This document shall in no way govern or modify any Terms and Conditions of Sale, which Terms and Conditions of Sale shall govern all conflicting information between the two documents.

Original instruction manual 50139049-a printed in February 2013.

WEEE Compliance

This product is required to comply with the European Union's Waste Electrical & Electronic Equipment (WEEE) Directive 2002/96/EC. It is marked with the following symbol:



Thermo Fisher Scientific has contracted with one or more recycling or disposal companies in each European Union (EU) Member State, and these companies should dispose of or recycle this product. See www.thermo.com/rohsweee for further information on Thermo Fisher Scientific's compliance with these Directives and the recyclers in your country.



Certificate of Containment Testing

Containment Testing of Rotor 75005719 MicroClick 30x2 in a Thermo Scientific Centrifuge



Report No. 194-12 B

Report Prepared For: Thermo Fisher Scientific

Issue Date: 30th October 2012

Test Summary

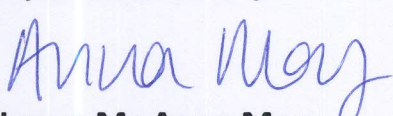
A 75005719 MicroClick 30x2 rotor was containment tested in a Thermo Scientific centrifuge at 15,000 rpm, using Annex AA of IEC 61010-2-20:2006 (2nd Ed.). The sealed rotor was shown to contain all contents.

Report Written By  Name: Ms Anna Moy Title: Biosafety Scientist	Report Authorised By  Name: Mrs Sara Speight Title: Senior Biosafety Scientist
--	--

Contents

Preface	7
Items Supplied	7
Intended Use	7
Precautions	8
Rotor Specifications	9
Thermo Scientific Heraeus Megafuge 8 Centrifuge	10
Thermo Scientific Sorvall ST 8 Centrifuge	11
Thermo Scientific SL 8 Centrifuge	13
Accessories	15
Thermo Scientific Auto-Lock Rotor Exchange	17
Rotor Installation	18
Removing the Rotor	19
Rotor Loading	21
Before a Run	22
Proper Loading	22
Improper Loading	23
Maximum Loading	23
Cycle Counter	24
Aerosol-tight Applications	25
Basic Principles	26
Fill Level	26
Checking the aerosol Tightness	26
Quick Test	26
Maintenance and Care	29
Cleaning Intervals	30
Cleaning	30
Disinfection	32
Decontamination	33
Autoclaving	34
Thermo Fisher Scientific Service	34

Contents

RCF-Values	35
Chemical Compatibility Chart	39
Contact	47

Preface

Before starting to use the rotor, read through these instruction manual carefully and follow the instructions.

Failure to follow the instructions and safety information in this instruction manual will result in the expiration of the seller's warranty.

Items Supplied

	Quantity	Check
MicroClick 30x2 Rotor	1	<input type="checkbox"/>
Bolt grease	1	<input type="checkbox"/>
Instruction manual	1	<input type="checkbox"/>

If any parts are missing, please contact the nearest Thermo Fisher Scientific representative.

Intended Use

This rotor is used in combination with the according centrifuge as a laboratory product designed to separate components by generation of Relative Centrifugal Force. It separates human samples (e.g. blood, urine and other body fluids) collected in appropriate containers, either alone or after addition of reagents or other additives.

The rotor in the centrifuge is designed to run other containers filled with chemicals, environmental samples and other non-human body samples.

If the rotor is used in a manner not specified by the manufacturer, the protection provided by the equipment may be impaired.

This rotor should be operated by trained specialists only.

Precautions

In order to ensure safe operation of the MicroClick 30x2 Rotor, the following general safety regulations must be followed:

- Do not remove the magnet at the rotor bottom
- Do not use rotors which show any signs of corrosion and/or cracks. Do not touch the electronic components of the rotor and do not make any changes to the electronic or mechanical components.
- Use only with rotors which have been loaded properly.
- Never overload the rotor.
- Use only accessories which have been approved by Thermo Fisher Scientific. Exceptions to this rule are commercially available glass or plastic centrifuge tubes, provided they have been approved for the speed or the RCF value of the rotor.
- If centrifuging any hazardous materials mind the „Laboratory Biosafety Manual“ of the World Health Organization (WHO).

When centrifuging microbiological samples from the Risk Group II (according to the "Laboratory Biosafety Manual" of the World Health Organization (WHO)), aerosol-tight biological seals have to be used.

Look on the internet page of the World Health Organization (www.who.int) for the „Laboratory Biosafety Manual“.

- Observe the safety instructions.

Pay particular attention to the following aspects:

- Rotor installation: Check that the rotor is locked properly into place before operating the centrifuge.
- Always balance the samples.

Maximum sample density at maximum speed: $1,2 \frac{\text{g}}{\text{cm}^3}$



This symbol refers to general hazards.
CAUTION means that material damage could occur.
WARNING means that injuries or material damage or contamination could occur.



This symbol refers to biological hazards.
Observe the information contained in the instruction manual to keep yourself and your environment safe.

Rotor Specifications

Contents

- “Thermo Scientific Heraeus Megafuge 8 Centrifuge” on page 10
- “Thermo Scientific Sorvall ST 8 Centrifuge” on page 11
- “Thermo Scientific SL 8 Centrifuge” on page 13

2 Rotor Specifications

Thermo Scientific Heraeus Megafuge 8 Centrifuge

Thermo Scientific Heraeus Megafuge 8 Centrifuge

Table 1. Heraeus 230V 50Hz/60Hz

Centrifuge	Heraeus® Megafuge® 8
Catalog #	75007211
Weight empty [kg]	1.5
Max. cycle number	50000
Maximum permissible load [g]	30 x 4
Maximum speed n_{\max} [rpm]	14000
Maximum RCF value at n_{\max}	21694
Max. / min. radius [cm]	9.9 / 6.4
Pitch angle [°]	45
Accel. / braking time [s]	28 / 35
Sample heating at n_{\max} [° C] referred to ambient temperature of 23 °C, running time 60 minutes	24
Aerosol-tight ¹	Yes
Permissible temperature range autoclavable °C	121

¹Tested by HPA, Porton-down, UK

Table 2. Heraeus 120V 60Hz

Centrifuge	Heraeus® Megafuge® 8
Catalog #	75007210
Weight empty [kg]	1.5
Max. cycle number	50000
Maximum permissible load [g]	30 x 4
Maximum speed n_{\max} [rpm]	14000
Maximum RCF value at n_{\max}	21694
Max. / min. radius [cm]	9.9 / 6.4
Pitch angle [°]	45
Accel. / braking time [s]	26 / 35
Sample heating at n_{\max} [° C] referred to ambient temperature of 23 °C, running time 60 minutes	24
Aerosol-tight ¹	Yes
Permissible temperature range autoclavable °C	121

¹Tested by HPA, Porton-down, UK

Thermo Scientific Sorvall ST 8 Centrifuge

Table 3. Sorvall 230V 50/60Hz

Centrifuge	Sorvall® 8
Catalog #	75007201
Weight empty [kg]	1.5
Max. cycle number	50000
Maximum permissible load [g]	30 x 4
Maximum speed n_{\max} [rpm]	14000
Maximum RCF value at n_{\max}	21694
Max. / min. radius [cm]	9.9 / 6.4
Pitch angle [°]	45
Accel. / braking time [s]	28 / 35
Sample heating at n_{\max} [° C] referred to ambient temperature of 23 °C, running time 60 minutes	24
Aerosol-tight ¹	Yes
Permissible temperature range autoclavable °C	121

¹Tested by HPA, Porton-down, UK

Table 4. Sorvall 120V 60Hz

Centrifuge	Sorvall® 8
Catalog #	75007200
Weight empty [kg]	1.5
Max. cycle number	50000
Maximum permissible load [g]	30 x 4
Maximum speed n_{\max} [rpm]	14000
Maximum RCF value at n_{\max}	21694
Max. / min. radius [cm]	9.9 / 6.4
Pitch angle [°]	45
Accel. / braking time [s]	26 / 35
Sample heating at n_{\max} [° C] referred to ambient temperature of 23 °C, running time 60 minutes	24
Aerosol-tight ¹	Yes
Permissible temperature range autoclavable °C	121

¹Tested by HPA, Porton-down, UK

2 Rotor Specifications

Thermo Scientific Sorvall ST 8 Centrifuge

Table 5. Sorvall 100V 60Hz

Centrifuge	Sorvall® 8
Catalog #	75007202
Weight empty [kg]	1.5
Max. cycle number	50000
Maximum permissible load [g]	30 x 4
Maximum speed n_{\max} [rpm]	14000
Maximum RCF value at n_{\max}	21694
Max. / min. radius [cm]	9.9 / 6.4
Pitch angle [°]	45
Accel. / braking time [s]	26 / 35
Sample heating at n_{\max} [° C] referred to ambient temperature of 23 °C, running time 60 minutes	24
Aerosol-tight ¹	Yes
Permissible temperature range autoclavable °C	121

¹Tested by HPA, Porton-down, UK

Thermo Scientific SL 8 Centrifuge

Table 6. Thermo Scientific 230V 50/60Hz

Centrifuge	SL 8
Catalog #	75007221
Weight empty [kg]	1.5
Max. cycle number	50000
Maximum permissible load [g]	30 x 4
Maximum speed n_{\max} [rpm]	14000
Maximum RCF value at n_{\max}	21694
Max. / min. radius [cm]	9.9 / 6.4
Pitch angle [°]	45
Accel. / braking time [s]	28 / 35
Sample heating at n_{\max} [° C] referred to ambient temperature of 23 °C, running time 60 minutes	24
Aerosol-tight ¹	Yes
Permissible temperature range autoclavable °C	121

¹Tested by HPA, Porton-down, UK

Table 7. Thermo Scientific 120V 60Hz

Centrifuge	SL 8
Catalog #	75007220
Weight empty [kg]	1.5
Max. cycle number	50000
Maximum permissible load [g]	30 x 4
Maximum speed n_{\max} [rpm]	14000
Maximum RCF value at n_{\max}	21694
Max. / min. radius [cm]	9.9 / 6.4
Pitch angle [°]	45
Accel. / braking time [s]	26 / 35
Sample heating at n_{\max} [° C] referred to ambient temperature of 23 °C, running time 60 minutes	24
Aerosol-tight ¹	Yes
Permissible temperature range autoclavable °C	121

¹Tested by HPA, Porton-down, UK

Accessories

Article	No.
Adapter 0.2 ml PCR Tube (Set of 30)	75005752
Adapter 0.25 ml Microtube (Set of 30)	75005754
Adapter 0.5 ml Microtube (Set of 30)	75005753
Replacement O-Ring	75005726
Replacement ClickSeal Biocontainment Lid	75005730

Thermo Scientific Auto-Lock Rotor Exchange

Contents

- “Rotor Installation” on page 18
- “Removing the Rotor” on page 19

Rotor Installation



CAUTION Unapproved or incorrectly combined accessories can cause serious damage to the centrifuge.

This rotor is equipped with an Auto-Lock™-system.

This system is used to automatically lock the rotor to the centrifuge spindle. The rotor does not have to be bolted onto the centrifuge spindle.

Proceed as follows:

1. Open the lid of the centrifuge and if necessary remove any dust, foreign objects or residue from the chamber.
Auto-Lock and O-ring must be clean and undamaged.

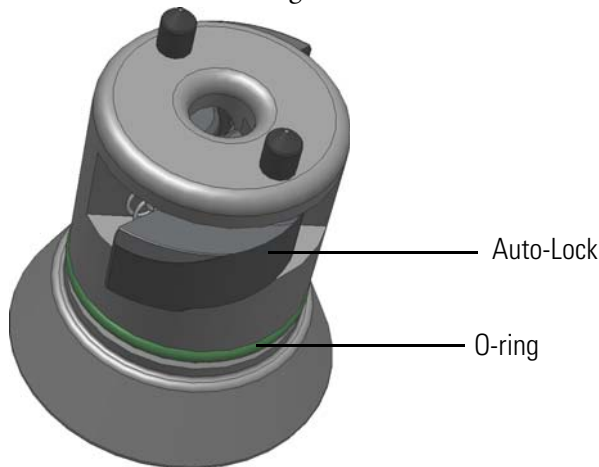

Figure 1. Auto-Lock

2. Hold the rotor over the centrifuge spindle and let it slide slowly down the centrifuge spindle. The rotor clicks automatically into place.



CAUTION Do not force the rotor onto the centrifuge spindle. If the rotor is very light, then it may be necessary to press it onto the centrifuge spindle with a small amount of pressure.

3. Check if the rotor is properly installed by lifting it slightly on the handle. If the rotor can be pulled up, then it must be reclamped to the centrifuge spindle.



WARNING If the rotor cannot be properly locked in place after several attempts, then the Auto-Lock is defective and you are not permitted to operate the rotor. Check for any damage to the rotor. Damaged rotors must not be used. Keep the hub area clear of objects.



CAUTION Check that the rotor is properly locked on the centrifuge spindle before each use by pulling it at its handle.



WARNING Be sure to check all seals before starting any aerosol-tight applications.

4. Close the centrifuge door.

Removing the Rotor

To remove the rotor, proceed as follows:

1. Open the centrifuge door.
2. Grab the rotor handle with both hands and press against the green Auto-Lock button. At the same time, pull the rotor directly upwards with both hands and remove it from the centrifuge spindle. Make sure not to jam the rotor while doing this.



Figure 2. Handling of Auto-Lock

Rotor Loading

Contents

- “Before a Run” on page 22
- “Proper Loading” on page 22
- “Improper Loading” on page 23
- “Maximum Loading” on page 23
- “Cycle Counter” on page 24

Before a Run

1. Please read and observe the safety instructions contained in these operating instructions and in the instructions for use.
2. Check the rotor and all accessory parts for damages such as cracks, scratches or traces of corrosion.
3. Check the rotor chamber, the centrifuge spindle and the Auto-Lock.
4. Check the rotor suitability using the “[Chemical Compatibility Chart](#)” on [page 39](#).
5. Make sure the tubes or bottles do not touch the bucket caps.
6. Check the rotor bolts and apply grease (part no. 75003786) before using for the first time.
7. Check that each bucket or microplate carrier can swing freely by moving it carefully with your hand. Weigh the bucket content (adapter and tube). Make sure you do not exceed the maximum compartment load.



CAUTION Always use identical bucket types in a rotor. Always be sure to use buckets of the same weight class, which is marked on the buckets themselves.

Proper Loading

To ensure safe operation of the centrifuge, the rotor must be evenly loaded at all times.

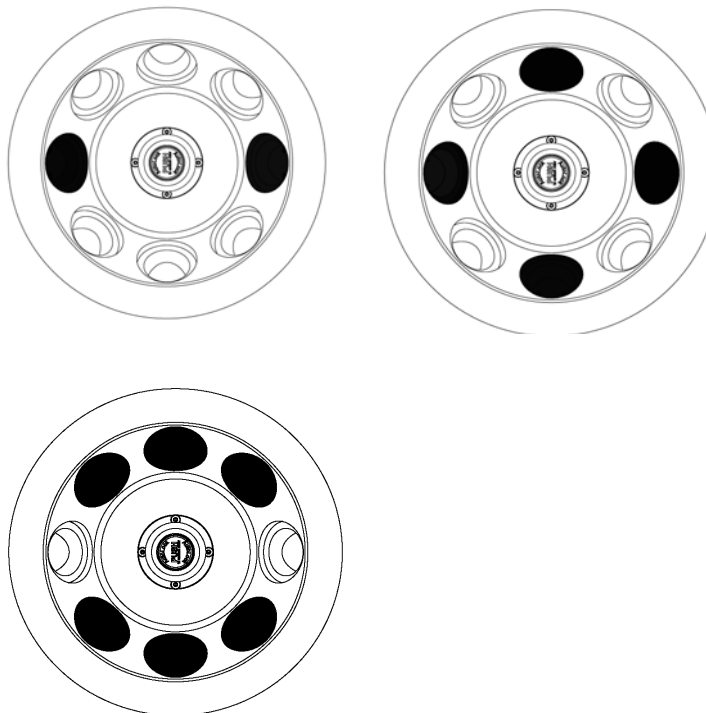

Make sure that the opposing receptacles are holding tubes of the same weight.

Improper Loading

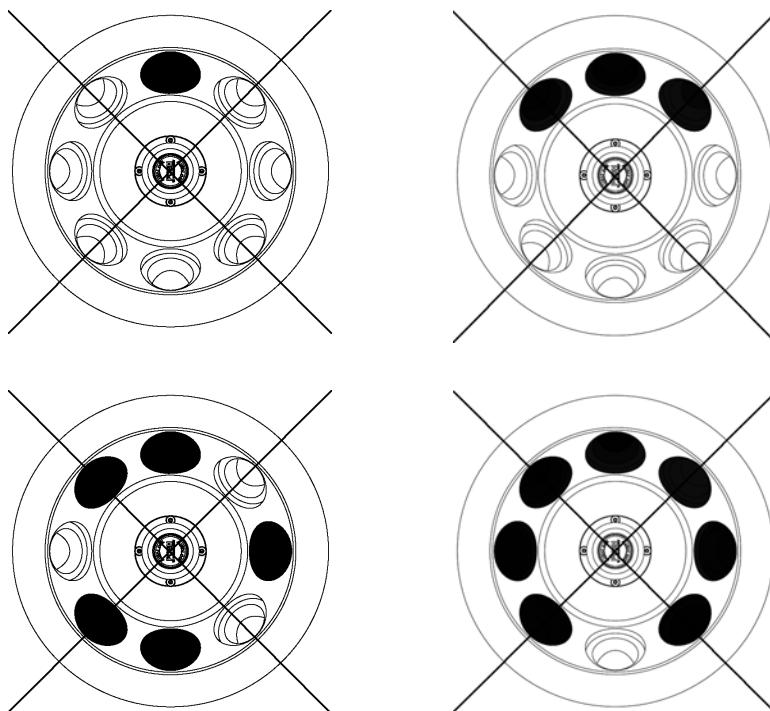

Maximum Loading

The rotor can run at high speeds. The rotor design has sufficient reserve stability even when spinning at top speed.

The safety system of the centrifuge requires that you do not overload the rotor.

There are two options available for centrifuging samples whose weight, including adapter, exceeds the maximum permissible load:

- Reduce the fill level.
- Reduce the speed.

Use the table or the formula:

$$n_{\text{adm}} = n_{\text{max}} \sqrt{\frac{\text{Maximum permissible load}}{\text{Effective load}}}$$

n_{adm} = admissible speed

n_{max} = maximum speed

Actual Load (g/cavity)	RPM _{max}
4.0	14000
4.2	16663
4.4	13348
4.6	13055
4.8	12780
5.0	12522
5.2	12279
5.4	12049
5.6	11832
5.8	11626
6.0	11431

Cycle Counter

The lifetime of rotors and buckets is dependent on the amount of mechanical load. Do not exceed the number of cycles recommended for rotors and buckets.

The maximum number of cycles is given in the rotor table in the rotor specification section.

The maximum number of cycles for buckets is marked on the buckets themselves.



WARNING Replace the rotor when the specified number of cycles is reached. Due to the mechanical load a rotor can break and thus damage the centrifuge. Replace the buckets when the specified number of cycles is reached.

Service life examples

Usage profile	Maximum service life at 50,000 cycles
frequent use 20 runs / day 220 days / year	7 years

Aerosol-tight Applications

Contents

- “Basic Principles” on page 26
- “Fill Level” on page 26
- “Checking the aerosol Tightness” on page 26

Basic Principles



CAUTION Biological seals are part of bio-containment systems as specified in international and national bio-safety guidelines, and cannot be relied on as the only means of safeguarding workers and the environment when handling pathogenic micro-organisms. Mind the „Laboratory Biosafety Manual“ of the World Health Organization (WHO) and the regulations in your country.



CAUTION When centrifuging hazardous samples, do not open aerosol-tight rotors unless placed in a safety cabinet.
Always bear in mind the maximum permitted fill levels.



WARNING Be sure to check all seals before starting any aerosol-tight applications.

Check that the sample containers are well suited for the desired centrifugation process.

Fill Level

The tubes are only to be filled to a level which ensures that the sample is unable to reach the top of the tube during centrifugation. Therefore fill the tube only 2/3 of the rated level.

Checking the aerosol Tightness

The aerosol tightness testing of the rotors took place according to the microbiological test process in accordance with the EN 61010-2-020 Appendix AA.

Whether or not a rotor is aerosol-tight depends primarily on proper handling.

Check as needed to make sure your rotor is aerosol-tight.

The careful inspection of the seals and seal surfaces for signs of wear and damage such as cracks, scratches and embrittlement is extremely important.

Aerosol-tight applications are not possible if the lids are open.

Aerosol-tightness requires the correct operation when filling the sample vessels and closing the rotor lid.

Quick Test

As a quick test, it is possible to test the aerosol-tight beaker and fixed-angle rotors using the following process:

1. Lubricate all seals lightly.
Always use the special grease (part no. 76003500) when lubricating the seals.
2. Fill the cavities or the rotor with approx. 10 ml of carbonated mineral water.

3. Close the bucket or the rotor as explained in the handling instructions.
4. Shake the bucket or the rotor vigorously using your hands.

This releases the carbonic acid gas which is bound in the water, resulting in excess pressure. Do not apply pressure to the lid when doing so!

Leaks can be detected by escaping water or the sound of escaping gas.

Replace the seals if you detect any leaks. Then repeat the test.

5. Dry the rotor, rotor cover and the cover seal.



CAUTION Prior to each use, the seals in the rotor are to be inspected in order to assure that they are correctly seated and are not worn or damaged. Damaged seals are to be replaced immediately. Replacement seals are supplied with the rotors and can also be re-ordered as a spare parts set. See table in “Accessories” on [page 15](#). When loading the rotor, ensure that the rotor lid closes securely. Damaged or clouded rotor covers are to be replaced immediately.

Maintenance and Care

Contents

- “Cleaning Intervals” on page 30
- “Cleaning” on page 30
- “Disinfection” on page 32
- “Decontamination” on page 33
- “Autoclaving” on page 34
- “Thermo Fisher Scientific Service” on page 34

Cleaning Intervals

For the sake of personal, environmental, and material protection, you have to clean and if necessary disinfect the centrifuge on a regular basis.

Maintenance	Recommended Interval
Clean rotor chamber	Daily or when polluted
Clean rotor	Daily or when polluted
Accessories	Daily or when polluted
Cabinet	Once per month
Ventilation holes	Every six months



CAUTION Refrain from using any other cleaning or decontamination procedure than those recommended here, if you are not entirely sure that the intended procedure is safe for the equipment.
Use only approved cleansers.
If in doubt, contact Thermo Fisher Scientific.

Cleaning

When cleaning the centrifuge:

- Use warm water with a neutral solvent.
- Never use caustic cleaning agents such as soap suds, phosphoric acid, bleaching solutions or scrubbing powder.
- Rinse the cavities out thoroughly.
- Use a soft brush without metal bristles to remove stubborn residue.
- Afterwards rinse with distilled water.
- Place the rotors on a plastic grate with their cavities pointing down.
- If drying boxes are used, the temperature must never exceed 50 °C, since higher temperatures could damage the material and shorten the lifetime of the parts.
- Use only disinfectants with a pH of 6-8.
- Dry aluminum parts off with a soft cloth.
- After cleaning, treat the entire surface of aluminum parts with corrosion protection oil (part no. 70009824). Also treat the cavities with oil.
- Store the aluminum parts at room temperature or in a cold-storage room with the cavities pointing down.



CAUTION Before using any cleaning or decontamination methods except those recommended by the manufacturer, users should check with the manufacturer that the proposed method will not damage the equipment.

Clean centrifuge and accessories as follows:

1. Open the centrifuge.
2. Turn off the centrifuge.
3. Pull out the power supply plug.
4. Grasp the rotor with both hands and lift it vertically off the centrifuge spindle.
5. Remove the centrifuge tubes and adapters.
6. Use a neutral cleaning agent with a pH 6-8 for cleaning.
7. Dry all of the rotors and accessories after cleaning with a cloth or in a warm air cabinet at a maximum temperature of 50 °C.
8. Clean the housing of the centrifuge as needed.
 - After cleaning, treat the entire surface of aluminum parts with corrosion protection oil (part no. 70009824). Also treat the cavities with oil.
 - Treat the bolt of the swing out rotor with bolt grease (part no. 75003786).



CAUTION When cleaning, do not allow liquids, especially organic solvents, to get on the drive shaft, the bearings, the Auto-Lock or the locks. Organic solvents break down the grease in the motor bearing. The drive shaft could freeze up.

After some applications there might be ice in the rotor chamber. Let the ice melt and drain it off. Clean the rotor chamber as described above.

Disinfection

Disinfect the centrifuge immediately whenever infectious material has spilled during centrifugation.



WARNING Infectious material can get into the centrifuge when a tube breaks or as a result of spills. Keep in mind the risk of infection when touching the rotor and take all necessary precautions.

In case of contamination, make sure that others are not put at risk.
Decontaminate the affected parts immediately.
Take other precautions if need be.

Use a sprayer whenever possible so that all surfaces are covered evenly.

The rotor chamber and the rotor should be treated preferably with a neutral disinfectant.



CAUTION Before using any cleaning or decontamination methods except those recommended by the manufacturer, users should check with the manufacturer that the proposed method will not damage the equipment.

Observe the safety precautions and handling instructions for the cleaning agents used.

Contact the Service Department of Thermo Fisher Scientific for questions regarding the use of other disinfectants.

Disinfect the rotor and accessories as follows:

1. Open the centrifuge.
2. Turn off the centrifuge.
3. Pull out the power supply plug.
4. Grasp the rotor with both hands and lift it vertically off the centrifuge spindle.
5. Remove the centrifuge tubes and adapters and dispose of them or disinfect them.
6. Treat the rotor and accessories according to the instructions for the disinfectant (spray or soak in solution). Adhere strictly to the given application times.
7. Be sure the disinfectant can drain off the rotor.
8. Rinse the rotor and rotor lid thoroughly with water and then rub down.
9. Dispose of the disinfectant according to the applicable guidelines.
10. Dry all of the rotors and accessories after cleaning with a cloth or in a warm air cabinet at a maximum temperature of 50 °C.
 - After cleaning, treat the entire surface of aluminum parts with corrosion protection oil (part no. 70009824). Also treat the cavities with oil.
 - Tread the bolt of the swing out rotor with bolt grease (part no. 75003786).

Decontamination

Decontaminate the centrifuge immediately whenever radioactive material has spilled during centrifugation.



WARNING Radioactive material can get into the centrifuge when a tube breaks or as a result of spills. Keep in mind the risk of infection when touching the rotor and take all necessary precautions.
In case of contamination, make sure that others are not put at risk.
Decontaminate the affected parts immediately.
Take other precautions if needed.



CAUTION Before using any cleaning or decontamination methods except those recommended by the manufacturer, users should check with the manufacturer that the proposed method will not damage the equipment.

For general radioactive decontamination use a solution of equal parts of 70% ethanol, 10% SDS and water.

Disinfect the rotor and accessories as follows:

1. Open the centrifuge.
2. Turn off the centrifuge.
3. Pull out the power supply plug.
4. Grasp the rotor with both hands and lift it vertically off the centrifuge spindle.
5. Remove the centrifuge tubes and adapters and dispose of them or disinfect them.
6. Rinse the rotor first with ethanol and then with de-ionized water.
 - Adhere strictly to the given application times.
7. Be sure the decontamination solution can drain off the rotor.
8. Rinse the rotor and accessories thoroughly with water.
9. Dispose of the decontamination solution according to the applicable guidelines.
10. Dry all of the rotors and accessories after cleaning with a cloth or in a warm air cabinet at a maximum temperature of 50 °C.
 - After cleaning, treat the entire surface of aluminum parts with corrosion protection oil (part no. 70009824). Also treat the cavities with oil.
 - Treat the bolt of the swing out rotor with bolt grease (part no. 75003786).

Autoclaving

1. Before autoclaving clean rotor and accessories.
2. Place the rotor on a flat surface.
 - Rotors and adapter can be autoclaved at 121 °C.
 - The maximum permissible autoclave cycle is 20 minutes at 121 °C.

Clean the rotor before autoclaving and rinse it with distilled water. Remove all accessories (tubes, adapters) from the rotor. Place the rotor on a flat surface.

Note No chemical additives are permitted in the steam.



CAUTION Never exceed the permitted temperature and duration when autoclaving. If the rotor shows signs of corrosion or wear, it must be replaced.



WARNING Dangerous materials through leaky seals. The O-ring of a sealed bucket will be damaged through heat exposure. Remove it before autoclaving a sealed bucket. Use a new O-ring.

Thermo Fisher Scientific Service

Thermo Fisher Scientific recommends having the centrifuge and accessories serviced once a year by an authorized service technician. The service technicians check the following:

- the electrical equipment
- the suitability of the set-up site
- the lid lock and the safety system
- the rotor
- the fixation of the rotor and the drive shaft

Thermo Fisher Scientific offers inspection and service contracts for this work.

RCF-Values

Speed (rpm)	R _{min}	R _{max}	RCF R _{min}	RCF R _{max}
300	6.4	9.9	6	10
400	6.4	9.9	11	18
500	6.4	9.9	18	28
600	6.4	9.9	26	40
700	6.4	9.9	35	54
800	6.4	9.9	46	71
900	6.4	9.9	58	90
1000	6.4	9.9	72	111
1100	6.4	9.9	87	134
1200	6.4	9.9	103	159
1300	6.4	9.9	121	187
1400	6.4	9.9	140	217
1500	6.4	9.9	161	249
1600	6.4	9.9	183	283
1700	6.4	9.9	207	320
1800	6.4	9.9	232	359
1900	6.4	9.9	258	400
2000	6.4	9.9	286	443
2100	6.4	9.9	316	488
2200	6.4	9.9	346	536
2300	6.4	9.9	379	586
2400	6.4	9.9	412	638
2500	6.4	9.9	447	692
2600	6.4	9.9	484	748
2700	6.4	9.9	522	807
2800	6.4	9.9	561	868
2900	6.4	9.9	602	931
3000	6.4	9.9	644	996
3100	6.4	9.9	688	1064
3200	6.4	9.9	733	1133
3300	6.4	9.9	779	1205
3400	6.4	9.9	827	1279

A RCF-Values

Speed (rpm)	R _{min}	R _{max}	RCF R _{min}	RCF R _{max}
3500	6.4	9.9	877	1356
3600	6.4	9.9	927	1434
3700	6.4	9.9	980	1515
3800	6.4	9.9	1033	1598
3900	6.4	9.9	1088	1683
4000	6.4	9.9	1145	1771
4100	6.4	9.9	1203	1861
4200	6.4	9.9	1262	1952
4300	6.4	9.9	1323	2047
4400	6.4	9.9	1385	2143
4500	6.4	9.9	1449	2241
4600	6.4	9.9	1514	2342
4700	6.4	9.9	1581	2445
4800	6.4	9.9	1649	2550
4900	6.4	9.9	1718	2657
5000	6.4	9.9	1789	2767
5100	6.4	9.9	1861	2879
5200	6.4	9.9	1935	2993
5300	6.4	9.9	2010	3109
5400	6.4	9.9	2086	3227
5500	6.4	9.9	2164	3348
5600	6.4	9.9	2244	3471
5700	6.4	9.9	2325	3596
5800	6.4	9.9	2407	3723
5900	6.4	9.9	2491	3853
6000	6.4	9.9	2576	3985
6100	6.4	9.9	2662	4118
6200	6.4	9.9	2750	4255
6300	6.4	9.9	2840	4393
6400	6.4	9.9	2931	4534
6500	6.4	9.9	3023	4676
6600	6.4	9.9	3117	4821
6700	6.4	9.9	3212	4969
6800	6.4	9.9	3309	5118
6900	6.4	9.9	3407	5270
7000	6.4	9.9	3506	5423
7100	6.4	9.9	3607	5579

Speed (rpm)	R _{min}	R _{max}	RCF R _{min}	RCF R _{max}
7200	6.4	9.9	3709	5738
7300	6.4	9.9	3813	5898
7400	6.4	9.9	3918	6061
7500	6.4	9.9	4025	6226
7600	6.4	9.9	4133	6393
7700	6.4	9.9	4242	6562
7800	6.4	9.9	4353	6734
7900	6.4	9.9	4466	6908
8000	6.4	9.9	4579	7084
8100	6.4	9.9	4695	7262
8200	6.4	9.9	4811	7442
8300	6.4	9.9	4929	7625
8400	6.4	9.9	5049	7810
8500	6.4	9.9	5170	7997
8600	6.4	9.9	5292	8186
8700	6.4	9.9	5416	8378
8800	6.4	9.9	5541	8571
8900	6.4	9.9	5668	8767
9000	6.4	9.9	5796	8965
9100	6.4	9.9	5925	9166
9200	6.4	9.9	6056	9368
9300	6.4	9.9	6189	9573
9400	6.4	9.9	6322	9780
9500	6.4	9.9	6458	9989
9600	6.4	9.9	6594	10200
9700	6.4	9.9	6732	10414
9800	6.4	9.9	6872	10630
9900	6.4	9.9	7013	10848
10000	6.4	9.9	7155	11068
10100	6.4	9.9	7299	11291
10200	6.4	9.9	7444	11515
10300	6.4	9.9	7591	11742
10400	6.4	9.9	7739	11971
10500	6.4	9.9	7889	12203
10600	6.4	9.9	8040	12436
10700	6.4	9.9	8192	12672
10800	6.4	9.9	8346	12910

A RCF-Values

Speed (rpm)	R _{min}	R _{max}	RCF R _{min}	RCF R _{max}
10900	6.4	9.9	8501	13150
11000	6.4	9.9	8658	13393
11100	6.4	9.9	8816	13637
11200	6.4	9.9	8975	13884
11300	6.4	9.9	9136	14133
11400	6.4	9.9	9299	14384
11500	6.4	9.9	9463	14638
11600	6.4	9.9	9628	14893
11700	6.4	9.9	9795	15151
11800	6.4	9.9	9963	15411
11900	6.4	9.9	10132	15674
12000	6.4	9.9	10303	15938
12100	6.4	9.9	10476	16205
12200	6.4	9.9	10650	16474
12300	6.4	9.9	10825	16745
12400	6.4	9.9	11002	17018
12500	6.4	9.9	11180	17294
12600	6.4	9.9	11360	17572
12700	6.4	9.9	11541	17852
12800	6.4	9.9	11723	18134
12900	6.4	9.9	11907	18419
13000	6.4	9.9	12092	18705
13100	6.4	9.9	12279	18994
13200	6.4	9.9	12467	19285
13300	6.4	9.9	12657	19579
13400	6.4	9.9	12848	19874
13500	6.4	9.9	13040	20172
13600	6.4	9.9	13234	20472
13700	6.4	9.9	13430	20774
13800	6.4	9.9	13626	21078
13900	6.4	9.9	13825	21385
14000	6.4	9.9	14024	21694

Chemical Compatibility Chart

CHEMICAL	MATERIAL	ALUMINUM	ANODIC COATING for ALUMINIUM	BUNA N	CELLULOSE ACETATE BUTYRATE	POLYURETHANE ROTOR PAINT	COMPOSITE Carbon Fiber/Epoxy	DELTRIN®	ETHYLENE PROPYLENE	GLASS	NEOPRENE	NORYL®	NYLON	PET ¹ , POLYCLEAR®, CLEARCRIMP®, CCCLEARCRIMP®	POLYALLUMER	POLYCARBONATE	POLYESTER, GLASS THERMOSET	POLYETHERIMIDE	POLYRTHYLENE	POLYPROPYLENE	POLYSULFONE	POLYVINYL CHLORIDE	RULON A®, TEFLON®	SILICONE RUBBER	STAINLESS STEEL	TITANIUM	TYGON®	VITON®	
2-mercaptoethanol	S	S	U	-	S	M	S	-	S	U	S	S	U	S	S	-	S	S	S	S	U	S	S	S	S	S	S	S	
Acetaldehyde	S	-	U	U	-	-	-	M	-	U	-	-	-	M	U	U	U	M	M	-	M	S	U	-	S	-	U		
Acetone	M	S	U	U	S	U	M	S	S	U	U	S	U	S	U	U	U	S	S	U	U	S	M	M	S	U	U		
Acetonitrile	S	S	U	-	S	M	S	-	S	S	U	S	U	M	U	U	-	S	M	U	U	S	S	S	S	U	U		
Alconox®	U	U	S	-	S	S	S	-	S	S	S	S	S	S	M	S	S	S	S	S	S	S	S	S	S	S	S	U	
Allyl Alcohol	-	-	-	U	-	-	S	-	-	-	-	-	S	-	S	S	M	S	S	S	-	M	S	-	-	S	-	-	
Aluminum Chloride	U	U	S	S	S	S	U	S	S	S	S	S	M	S	S	S	S	-	S	S	S	S	S	M	U	U	S	S	
Formic Acid (100%)	-	S	M	U	-	-	U	-	-	-	-	-	U	-	S	M	U	U	S	S	-	U	S	-	U	S	-	U	
Ammonium Acetate	S	S	U	-	S	S	S	-	S	S	S	S	S	S	S	U	-	S	S	S	S	S	S	S	S	S	S	S	
Ammonium Carbonate	M	S	U	S	S	S	S	S	S	S	S	S	S	S	U	U	-	S	S	S	S	S	S	S	M	S	S	S	
Ammonium Hydroxide (10%)	U	U	S	U	S	S	M	S	S	S	S	S	S	-	S	U	M	S	S	S	S	S	S	S	S	S	S	M	S
Ammonium Hydroxide (28%)	U	U	S	U	S	U	M	S	S	S	S	S	S	U	S	U	M	S	S	S	S	S	S	S	S	S	S	M	S
Ammonium Hydroxide (conc.)	U	U	U	U	S	U	M	S	-	S	-	S	U	S	U	U	S	S	S	-	M	S	S	S	S	S	-	U	
Ammonium Phosphate	U	-	S	-	S	S	S	S	S	S	S	S	S	-	S	S	M	-	S	S	S	S	S	S	M	S	S	S	
Ammonium Sulfate	U	M	S	-	S	S	U	S	S	S	S	S	S	S	S	S	S	-	S	S	S	S	S	S	U	S	S	U	
Amyl Alcohol	S	-	M	U	-	-	S	S	-	M	-	S	-	M	S	S	S	S	M	-	-	-	U	-	S	-	M		
Aniline	S	S	U	U	S	U	S	M	S	U	U	U	U	U	U	U	-	S	M	U	U	S	S	S	S	U	S		
Sodium Hydroxide (<1%)	U	-	M	S	S	S	-	-	S	M	S	S	-	S	M	M	S	S	S	S	S	S	S	M	S	S	-	U	
Sodium Hydroxide (10%)	U	-	M	U	-	-	U	-	M	M	S	S	U	S	U	U	S	S	S	S	S	S	M	S	S	-	U		

B Chemical Compatibility Chart

CHEMICAL	MATERIAL	ALUMINUM	ANODIC COATING for ALUMINIUM	BUNA N	CELLULOSE ACETATE BUTYRATE	POLYURETHANE ROTOR PAINT	COMPOSITE Carbon Fiber/Epoxy DELRIN®	ETHYLENE PROPYLENE	GLASS	NEOPRENE	NORYL®	NYLON	PET ¹ , POLYCLEAR®, CLEARCRIMP®, CCCLEARCRIMP®	POLYALLOMER	POLYCARBONATE	POLYESTER, GLASS THERMOSET	POLYETHERIMIDE	POLYTHYLENE	POLYPROPYLENE	POLYSULFONE	POLYVINYL CHLORIDE	RULON A®, TEFLON®	SILICONE RUBBER	STAINLESS STEEL	TITANIUM	TYGON®	VITON®
Barium Salts	M	U	S	-	S	S	S	S	S	S	S	S	S	S	S	M	-	S	S	S	S	S	S	M	S	S	S
Benzene	S	S	U	U	S	U	M	U	S	U	U	S	U	U	U	M	U	M	U	U	U	S	U	U	S	U	S
Benzyl Alcohol	S	-	U	U	-	-	M	M	-	M	-	S	U	U	U	U	U	U	U	-	M	S	M	-	S	-	S
Boric Acid	U	S	S	M	S	S	U	S	S	S	S	S	S	S	S	S	U	S	S	S	S	S	S	S	S	S	S
Cesium Acetate	M	-	S	-	S	S	S	-	S	S	S	S	-	S	S	-	-	S	S	S	S	S	S	M	S	S	S
Cesium Bromide	M	S	S	-	S	S	S	-	S	S	S	S	S	S	S	-	-	S	S	S	S	S	S	M	S	S	S
Cesium Chloride	M	S	S	U	S	S	S	-	S	S	S	S	S	S	S	-	-	S	S	S	S	S	S	M	S	S	S
Cesium Formate	M	S	S	-	S	S	S	-	S	S	S	S	S	S	S	-	-	S	S	S	S	S	S	M	S	S	S
Cesium Iodide	M	S	S	-	S	S	S	-	S	S	S	S	S	S	S	-	-	S	S	S	S	S	S	M	S	S	S
Cesium Sulfate	M	S	S	-	S	S	S	-	S	S	S	S	S	S	S	-	-	S	S	S	S	S	S	M	S	S	S
Chloroform	U	U	U	U	S	S	M	U	S	U	U	M	U	M	U	U	U	M	M	U	U	S	U	U	U	M	S
Chromic Acid (10%)	U	-	U	U	S	U	U	-	S	S	S	U	S	S	M	U	M	S	S	U	M	S	M	U	S	S	S
Chromic Acid (50%)	U	-	U	U	-	U	U	-	-	-	S	U	U	S	M	U	M	S	S	U	M	S	-	U	M	-	S
Cresol Mixture	S	S	U	-	-	-	S	-	S	U	U	U	U	U	U	-	-	U	U	-	U	S	S	S	S	U	S
Cyclohexane	S	S	S	-	S	S	S	U	S	U	S	S	U	U	U	M	S	M	U	M	M	S	U	M	M	U	S
Deoxycholate	S	S	S	-	S	S	S	-	S	S	S	S	S	S	S	-	-	S	S	S	S	S	S	S	S	S	S
Distilled Water	S	S	S	S	S	S	S	S	S	S	S	S	S	S	S	S	S	S	S	S	S	S	S	S	S	S	S
Dextran	M	S	S	S	S	S	S	-	S	S	S	S	S	S	S	S	S	S	S	S	S	S	S	M	S	S	S
Diethyl Ether	S	S	U	U	S	S	S	U	S	U	U	S	U	U	U	U	U	U	U	U	U	S	S	S	S	M	U
Diethyl Ketone	S	-	U	U	-	-	M	-	S	U	-	S	-	M	U	U	U	M	M	-	U	S	-	-	S	U	U
Diethylpyrocarbonate	S	S	U	-	S	S	S	-	S	S	U	S	U	S	U	-	-	S	S	S	M	S	S	S	S	S	S
Dimethylsulfoxide	S	S	U	U	S	S	S	-	S	U	S	S	U	S	U	U	-	S	S	U	U	S	S	S	S	U	U
Dioxane	M	S	U	U	S	S	M	M	S	U	U	S	U	M	U	U	-	M	M	M	U	S	S	S	S	U	U
Ferric Chloride	U	U	S	-	-	-	M	S	-	M	-	S	-	S	-	-	-	S	S	-	-	-	M	U	S	-	S
Acetic Acid (Glacial)	S	S	U	U	S	S	U	M	S	U	S	U	U	U	U	U	M	S	U	M	U	S	U	U	S	-	U

CHEMICAL	MATERIAL	ALUMINUM	ANODIC COATING for ALUMINIUM	BUNA N	CELLULOSE ACETATE BUTYRATE	POLYURETHANE ROTOR PAINT	COMPOSITE Carbon Fiber/Epoxy	DELTRIN®	ETHYLENE PROPYLENE	GLASS	NEOPRENE	NORYL®	NYLON	PET ¹ , POLYCLEAR®, CLEARCRIMP®, CCCLEARCRIMP®	POLYALLOMER	POLYCARBONATE	POLYESTER, GLASS THERMOSET	POLYETHERIMIDE	POLYRTHYLENE	POLYPROPYLENE	POLYSULFONE	POLYVINYL CHLORIDE	RULON A®, TEFLON®	SILICONE RUBBER	STAINLESS STEEL	TITANIUM	TYGON®	VITON®
Acetic Acid (5%)	S	S	M	S	S	S	M	S	S	S	S	S	S	M	S	S	S	S	S	S	S	M	S	S	M	S	S	M
Acetic Acid (60%)	S	S	U	U	S	S	U	-	S	M	S	U	U	M	U	S	M	S	M	S	M	S	M	U	S	M	U	
Ethyl Acetate	M	M	U	U	S	S	M	M	S	S	U	S	U	M	U	U	-	S	S	U	U	S	M	M	S	U	U	
Ethyl Alcohol (50%)	S	S	S	S	S	S	M	S	S	S	S	S	U	S	U	S	S	S	S	S	S	S	S	S	M	S	M	U
Ethyl Alcohol (95%)	S	S	S	U	S	S	M	S	S	S	S	S	U	S	U	-	S	S	S	M	S	S	S	U	S	M	U	
Ethylene Dichloride	S	-	U	U	-	-	S	M	-	U	U	S	U	U	U	U	U	U	U	-	U	S	U	-	S	-	S	
Ethylene Glycol	S	S	S	S	S	S	S	S	S	S	S	S	-	S	U	S	S	S	S	S	S	S	S	S	M	S	M	S
Ethylene Oxide Vapor	S	-	U	-	-	U	-	-	S	U	-	S	-	S	M	-	-	S	S	S	U	S	U	S	S	S	U	
Ficoll-Hypaque®	M	S	S	-	S	S	S	-	S	S	S	S	-	S	S	-	S	S	S	S	S	S	S	M	S	S	S	
Hydrofluoric Acid (10%)	U	U	U	M	-	-	U	-	-	U	U	S	-	S	M	U	S	S	S	S	M	S	U	U	U	-	-	
Hydrofluoric Acid (50%)	U	U	U	U	-	-	U	-	-	U	U	U	U	S	U	U	U	S	S	M	M	S	U	U	U	-	M	
Hydrochloric Acid (conc.)	U	U	U	U	-	U	U	M	-	U	M	U	U	M	U	U	U	-	S	-	U	S	U	U	U	-	-	
Formaldehyde (40%)	M	M	M	S	S	S	S	M	S	S	S	S	M	S	S	S	U	S	S	M	S	S	S	M	S	M	U	
Glutaraldehyde	S	S	S	S	-	-	S	-	S	S	S	S	S	S	S	-	-	S	S	S	-	-	S	S	S	-	-	
Glycerol	M	S	S	-	S	S	S	S	S	S	S	S	S	S	S	S	-	S	S	S	S	S	S	S	S	S	S	
Guanidine Hydrochloride	U	U	S	-	S	S	S	-	S	S	S	S	S	S	S	-	-	S	S	S	S	S	S	U	S	S	S	
Haemo-Sol®	S	S	S	-	-	-	S	-	S	S	S	S	S	S	S	-	-	S	S	S	S	S	S	S	S	S	S	
Hexane	S	S	S	-	S	S	S	-	S	S	U	S	U	M	U	S	S	U	S	S	M	S	U	S	S	U	S	
Isobutyl Alcohol	-	-	M	U	-	-	S	S	-	U	-	S	U	S	S	M	S	S	S	-	S	S	S	-	S	-	S	
Isopropyl Alcohol	M	M	M	U	S	S	S	S	U	S	S	U	S	U	M	S	S	S	S	S	S	S	S	M	M	M	S	
Iodoacetic Acid	S	S	M	-	S	S	S	-	S	M	S	S	M	S	S	-	M	S	S	S	S	S	M	S	S	M	M	
Potassium Bromide	U	S	S	-	S	S	S	-	S	S	S	S	S	S	S	S	S	S	S	-	S	S	S	M	S	S	S	
Potassium Carbonate	M	U	S	S	S	S	S	-	S	S	S	S	S	S	U	S	S	S	S	S	S	S	S	S	S	S	S	
Potassium Chloride	U	S	S	-	S	S	S	S	S	S	S	S	S	S	S	-	S	S	S	S	S	S	S	U	S	S	S	

B Chemical Compatibility Chart

CHEMICAL	MATERIAL	ALUMINUM	ANODIC COATING for ALUMINIUM	BUNA N	CELLULOSE ACETATE BUTYRATE	POLYURETHANE ROTOR PAINT	COMPOSITE Carbon Fiber/Epoxy	DELRIN®	ETHYLENE PROPYLENE	GLASS	NEOPRENE	NORYL®	NYLON	PET ¹ , POLYCLEAR®, CLEARCRIMP®, CCCLEARCRIMP®	POLYALLOMER	POLYCARBONATE	POLYESTER, GLASS THERMOSET	POLYETHERIMIDE	POLYTHYLENE	POLYPROPYLENE	POLYSULFONE	POLYVINYL CHLORIDE	RULON A®, TEFLON®	SILICONE RUBBER	STAINLESS STEEL	TITANIUM	TYGON®	VITON®	
Potassium Hydroxide (5%)		U	U	S	S	S	S	M	-	S	S	S	S	-	S	U	S	S	S	S	S	S	S	M	U	M	S	U	
Potassium Hydroxide (conc.)		U	U	M	U	-	-	M	-	M	S	S	-	U	M	U	U	U	S	M	-	M	U	-	U	U	-	U	
Potassium Permanganate		S	S	S	-	S	S	S	-	S	S	S	U	S	S	S	M	-	S	M	S	U	S	S	M	S	U	S	
Calcium Chloride		M	U	S	S	S	S	S	S	S	S	S	S	S	S	M	S	-	S	S	S	S	S	S	M	S	S	S	
Calcium Hypochlorite		M	-	U	-	S	M	M	S	-	M	-	S	-	S	M	S	-	S	S	S	M	S	M	U	S	-	S	
Kerosene		S	S	S	-	S	S	S	U	S	M	U	S	U	M	M	S	-	M	M	M	S	S	U	S	S	U	S	
Sodium Chloride (10%)		S	-	S	S	S	S	S	S	-	-	-	S	S	S	S	S	-	S	S	S	S	-	S	S	M	-	S	
Sodium Chloride (sat'd)		U	-	S	U	S	S	S	-	-	-	-	S	S	S	S	S	-	S	S	-	S	-	S	S	M	-	S	
Carbon Tetrachloride		U	U	M	S	S	U	M	U	S	U	U	S	U	M	U	S	S	M	M	S	M	M	M	M	U	S	S	
Aqua Regia		U	-	U	U	-	-	U	-	-	-	-	-	U	U	U	U	U	U	U	U	-	-	-	-	-	S	-	M
Solution 555 (20%)		S	S	S	-	-	-	S	-	S	S	S	S	S	S	S	S	-	-	S	S	S	-	S	S	S	S	S	
Magnesium Chloride		M	S	S	-	S	S	S	S	S	S	S	S	S	S	S	S	S	S	S	S	S	S	S	M	S	S	S	
Mercaptoacetic Acid		U	S	U	-	S	M	S	-	S	M	S	U	U	U	U	-	S	U	U	S	M	S	U	S	S	S	S	
Methyl Alcohol		S	S	S	U	S	S	M	S	S	S	S	S	U	S	U	M	S	S	S	S	S	S	S	M	S	M	U	
Methylene Chloride		U	U	U	U	M	S	S	U	S	U	U	S	U	U	U	U	U	M	U	U	U	S	S	M	U	S	U	
Methyl Ethyl Ketone		S	S	U	U	S	S	M	S	S	U	U	S	U	S	U	U	U	S	S	U	U	S	S	S	S	U	U	
Metrizamide®		M	S	S	-	S	S	S	-	S	S	S	S	-	S	S	-	-	S	S	S	S	S	S	M	S	S	S	
Lactic Acid (100%)		-	-	S	-	-	-	-	-	-	M	S	U	-	S	S	S	M	S	S	-	M	S	M	S	S	-	S	
Lactic Acid (20%)		-	-	S	S	-	-	-	-	-	M	S	M	-	S	S	S	S	S	S	S	M	S	M	S	S	-	S	
N-Butyl Alcohol		S	-	S	U	-	-	S	-	-	S	M	-	U	S	M	S	S	S	S	M	M	S	M	-	S	-	S	
N-Butyl Phthalate		S	S	U	-	S	S	S	-	S	U	U	S	U	U	U	M	-	U	U	S	U	S	M	M	S	U	S	
N, N-Dimethylformamide		S	S	S	U	S	M	S	-	S	S	U	S	U	S	U	U	-	S	S	U	U	S	M	S	S	S	U	

CHEMICAL	MATERIAL	ALUMINUM	ANODIC COATING for ALUMINIUM	BUNA N	CELLULOSE ACETATE BUTYRATE	POLYURETHANE ROTOR PAINT	COMPOSITE Carbon Fiber/Epoxy	DELRIN®	ETHYLENE PROPYLENE	GLASS	NEOPRENE	NORYL®	NYLON	PET ¹ , POLYCLEAR®, CLEARCRIMP®, CCCLEARCRIMP®	POLYALLOMER	POLYCARBONATE	POLYESTER, GLASS THERMOSET	POLYETHERIMIDE	POLYRTHYLENE	POLYPROPYLENE	POLYSULFONE	POLYVINYL CHLORIDE	RULON A®, TEFLON®	SILICONE RUBBER	STAINLESS STEEL	TITANIUM	TYGON®	VITON®
Sodium Borate	M	S	S	S	S	S	S	S	S	S	S	S	U	S	S	S	S	-	S	S	S	S	S	S	M	S	S	S
Sodium Bromide	U	S	S	-	S	S	S	-	S	S	S	S	S	S	S	S	S	-	S	S	S	S	S	S	M	S	S	S
Sodium Carbonate (2%)	M	U	S	S	S	S	S	S	S	S	S	S	S	S	S	U	S	S	S	S	S	S	S	S	S	S	S	S
Sodium Dodecyl Sulfate	S	S	S	-	S	S	S	-	S	S	S	S	S	S	S	S	-	S	S	S	S	S	S	S	S	S	S	S
Sodium Hypochlorite (5%)	U	U	M	S	S	M	U	S	S	M	S	S	S	S	M	S	S	S	S	M	S	S	S	M	U	S	M	S
Sodium Iodide	M	S	S	-	S	S	S	-	S	S	S	S	S	S	S	S	-	-	S	S	S	S	S	S	M	S	S	S
Sodium Nitrate	S	S	S	-	S	S	S	S	S	S	S	S	S	S	S	S	S	-	S	S	S	S	S	S	U	S	S	S
Sodium Sulfate	U	S	S	-	S	S	S	S	S	S	S	S	S	S	S	S	S	S	S	S	S	S	S	S	M	S	S	S
Sodium Sulfide	S	-	S	S	-	-	-	S	-	-	-	S	S	S	U	U	-	-	S	-	-	-	S	S	M	-	S	
Sodium Sulfite	S	S	S	-	S	S	S	S	M	S	S	S	S	S	S	S	M	-	S	S	S	S	S	S	S	S	S	S
Nickel Salts	U	S	S	S	S	S	-	S	S	S	-	-	S	S	S	S	S	-	S	S	S	S	S	S	M	S	S	S
Oils (Petroleum)	S	S	S	-	-	-	S	U	S	S	S	S	U	U	M	S	M	U	U	S	S	S	S	U	S	S	S	S
Oils (Other)	S	-	S	-	-	-	S	M	S	S	S	S	U	S	S	S	S	U	S	S	S	S	S	-	S	S	M	S
Oleic Acid	S	-	U	S	S	S	U	U	S	U	S	S	M	S	S	S	S	S	S	S	S	S	S	M	U	S	M	M
Oxalic Acid	U	U	M	S	S	S	U	S	S	S	S	S	U	S	U	S	S	S	S	S	S	S	S	S	U	M	S	S
Perchloric Acid (10%)	U	-	U	-	S	U	U	-	S	M	M	-	-	M	U	M	S	M	M	-	M	S	U	-	S	-	S	
Perchloric Acid (70%)	U	U	U	-	-	U	U	-	S	U	M	U	U	M	U	U	U	M	M	U	M	S	U	U	S	U	S	
Phenol (5%)	U	S	U	-	S	M	M	-	S	U	M	U	U	S	U	M	S	M	S	U	U	S	U	M	M	M	S	
Phenol (50%)	U	S	U	-	S	U	M	-	S	U	M	U	U	U	U	U	S	U	M	U	U	S	U	U	U	M	S	
Phosphoric Acid (10%)	U	U	M	S	S	S	U	S	S	S	S	U	-	S	S	S	S	S	S	S	S	S	S	U	M	U	S	
Phosphoric Acid (conc.)	U	U	M	M	-	-	U	S	-	M	S	U	U	M	M	S	S	S	M	S	M	S	U	M	U	-	S	
Physiologic Media (Serum, Urine)	M	S	S	S	-	-	S	-	S	S	S	S	S	S	S	S	S	S	S	S	S	S	S	S	S	S	S	S
Picric Acid	S	S	U	-	S	M	S	S	S	M	S	U	S	S	S	U	S	S	S	S	U	S	U	M	S	M	S	
Pyridine (50%)	U	S	U	U	S	U	U	-	U	S	S	U	U	M	U	U	-	U	S	M	U	S	S	U	U	U	U	

B Chemical Compatibility Chart

CHEMICAL	MATERIAL	ALUMINUM	ANODIC COATING for ALUMINIUM	BUNA N	CELLULOSE ACETATE BUTYRATE	POLYURETHANE ROTOR PAINT	COMPOSITE Carbon Fiber/Epoxy	DELRIN®	ETHYLENE PROPYLENE	GLASS	NEOPRENE	NORYL®	NYLON	PET ¹ , POLYCLEAR®, CLEARCRIMP®, CCCLEARCRIMP®	POLYALLOMER	POLYCARBONATE	POLYESTER, GLASS THERMOSET	POLYETHERIMIDE	POLYRTHYLENE	POLYPROPYLENE	POLYSULFONE	POLYVINYL CHLORIDE	RULON A®, TEFLON®	SILICONE RUBBER	STAINLESS STEEL	TITANIUM	TYGON®	VITON®
Rubidium Bromide	M	S	S	-	S	S	S	-	S	S	S	S	S	S	S	-	-	S	S	S	S	S	S	M	S	S	S	
Rubidium Chloride	M	S	S	-	S	S	S	-	S	S	S	S	S	S	S	-	-	S	S	S	S	S	S	M	S	S	S	
Sucrose	M	S	S	-	S	S	S	S	S	S	S	S	S	S	S	S	S	S	S	S	S	S	S	S	S	S	S	
Sucrose, Alkaline	M	S	S	-	S	S	S	-	S	S	S	S	S	S	U	S	S	S	S	S	S	S	S	M	S	S	S	
Sulfosalicylic Acid	U	U	S	S	S	S	S	-	S	S	S	U	S	S	S	-	S	S	S	-	S	S	S	U	S	S	S	
Nitric Acid (10%)	U	S	U	S	S	U	U	-	S	U	S	U	-	S	S	S	S	S	S	S	S	S	M	S	S	S	S	
Nitric Acid (50%)	U	S	U	M	S	U	U	-	S	U	S	U	U	M	M	U	M	M	M	S	S	S	U	S	S	M	S	
Nitric Acid (95%)	U	-	U	U	-	U	U	-	-	U	U	U	U	M	U	U	U	U	M	U	U	S	U	S	S	-	S	
Hydrochloric Acid (10%)	U	U	M	S	S	S	U	-	S	S	S	U	U	S	U	S	S	S	S	S	S	S	S	U	M	S	S	
Hydrochloric Acid (50%)	U	U	U	U	S	U	U	-	S	M	S	U	U	M	U	U	S	S	S	S	S	M	S	M	U	U	M	M
Sulfuric Acid (10%)	M	U	U	S	S	U	U	-	S	S	M	U	S	S	S	S	S	S	S	S	S	S	S	U	U	U	S	S
Sulfuric Acid (50%)	M	U	U	U	S	U	U	-	S	S	M	U	U	S	U	U	M	S	S	S	S	S	U	U	U	M	S	
Sulfuric Acid (conc.)	M	U	U	U	-	U	U	M	-	-	M	U	U	S	U	U	U	M	S	U	M	S	U	U	U	-	S	
Stearic Acid	S	-	S	-	-	-	S	M	S	S	S	S	-	S	S	S	S	S	S	S	S	S	M	M	S	S	S	
Tetrahydrofuran	S	S	U	U	S	U	U	M	S	U	U	S	U	U	U	-	M	U	U	U	U	S	U	S	S	U	U	
Toluene	S	S	U	U	S	S	M	U	S	U	U	S	U	U	U	S	U	M	U	U	U	S	U	S	U	U	M	
Trichloroacetic Acid	U	U	U	-	S	S	U	M	S	U	S	U	U	S	M	-	M	S	S	U	U	S	U	U	U	M	U	
Trichloroethane	S	-	U	-	-	-	M	U	-	U	-	S	U	U	U	U	U	U	U	U	U	S	U	-	S	-	S	
Trichloroethylene	-	-	U	U	-	-	-	U	-	U	-	S	U	U	U	U	U	U	U	U	U	S	U	-	U	-	S	
Trisodium Phosphate	-	-	-	S	-	-	M	-	-	-	-	-	-	S	-	-	S	S	S	-	-	S	-	-	S	-	S	
Tris Buffer (neutral pH)	U	S	S	S	S	S	S	-	S	S	S	S	S	S	S	S	S	S	S	S	S	S	S	S	S	S	S	S
Triton X-100®	S	S	S	-	S	S	S	-	S	S	S	S	S	S	S	S	S	S	S	S	S	S	S	S	S	S	S	S
Urea	S	-	U	S	S	S	S	-	-	-	-	S	S	S	M	S	S	S	S	S	-	S	S	M	S	-	S	
Hydrogen Peroxide (10%)	U	U	M	S	S	U	U	-	S	S	S	U	S	S	S	M	U	S	S	S	S	S	M	S	U	S	S	

CHEMICAL	MATERIAL	ALUMINUM	ANODIC COATING for ALUMINIUM	BUNA N	CELLULOSE ACETATE BUTYRATE	POLYURETHANE ROTOR PAINT	COMPOSITE Carbon Fiber/Epoxy	DELTRIN®	ETHYLENE PROPYLENE	GLASS	NEOPRENE	NORYL®	NYLON	PET ¹ , POLYCLEAR®, CLEARCRIMP®, CCCLEARCRIMP®	POLYALLOMER	POLYCARBONATE	POLYESTER, GLASS THERMOSET	POLYETHERIMIDE	POLYRTHYLENE	POLYPROPYLENE	POLYSULFONE	POLYVINYL CHLORIDE	RULON A®, TEFLON®	SILICONE RUBBER	STAINLESS STEEL	TITANIUM	TYGON®	VITON®	
Hydrogen Peroxide (3%)		S	M	S	S	S	-	S	-	S	S	S	S	S	S	S	S	M	S	S	S	S	S	S	S	S	S	S	S
Xylene		S	S	U	S	S	S	M	U	S	U	U	U	U	U	U	M	U	M	U	U	U	S	U	M	S	U	S	
Zinc Chloride		U	U	S	S	S	S	U	S	S	S	S	S	S	S	S	S	S	S	S	S	S	S	S	U	S	S	S	
Zinc Sulfate		U	S	S	-	S	S	S	S	S	S	S	S	S	S	S	S	S	S	S	S	S	S	S	S	S	S	S	
Citric Acid (10%)		M	S	S	M	S	S	M	S	S	S	S	S	S	S	S	S	M	S	S	S	S	S	S	S	S	S	S	

¹Polyethyleneterephthalate

Key

S Satisfactory

M M = Moderate attack, may be satisfactory for use in centrifuge depending on length of exposure, speed involved, etc.; suggest testing under actual conditions of use.

U U = Unsatisfactory, not recommended.

-- No data available. Because no organized chemical resistance data exists for materials under the stress of centrifugation, when in doubt we recommend pretesting sample lots. suggest testing, using sample to avoid loss of valuable material.

Chemical resistance data is included only as a guide to product use.

Contact

Country	Telephone number
United States / Canada	+1 866 984 3766
Latin America	+1 866 984 3766
Austria	+43 1 801 40 0
Belgium	+32 53 73 42 41
France	+33 2 2803 2180
Germany	0800 1 536 376 +49 6184 90 6000
Italy	+39 02 95059 552
Netherlands	+31 76 579 55 55
Nordic / Baltic Countries / CIS	+358 9 329 10200
Russia	+7 812 703 42 15
Spain / Portugal	+34 93 223 09 18
Switzerland	+41 44 454 12 22
UK / Ireland	+44 870 609 9203
China	+86 21 6865 4588 +86 10 8419 3588
India	+91 22 6716 2200
Japan	+81 45 453 9220
Other Asian Countries	+852 2885 4613
Australia	+61 39757 4300
New Zealand	+64 9 980 6700
Countries not listed	+49 6184 90 6000 +33 2 2803 2180

Index

A

Accessories 15
Aerosol-tight Applications 25
Autoclaving 34
Auto-Lock™ 17

B

Basic Principles 26
Before a Run 22

C

Checking the aerosol Tightness 26
Chemical Compatibility Chart 39
Cleaning 30
Cleaning Intervals 30
Cycle Counter 24

D

Decontamination 33

F

Fill Level 26

H

Heraeus 10

I

Improper Loading 23
Intended Use 7
Items Supplied 7

M

Maintenance and Care 29
Maximum Loading 23

P

Precautions 8
Preface 7
Proper Loading 22

R

RCF-Values 35
Removing the Rotor 19
Rotor Installation 18
Rotor Loading 21
Rotor Specifications 9

S

Sorvall 11

T

Thermo Fisher Scientific Service 34

W

WEEE compliance 3

