



Thermo Fisher Scientific

HIGHPlate™

Instruction Manual

50119962-4

October 2009

© 2009 Thermo Fisher Scientific Inc. All rights reserved.

AutoLock™ is either a registered trademark or a trademark of Thermo Fisher Scientific.

All other trademarks are the property of Thermo Fisher Scientific Inc. and its subsidiaries.

Thermo Fisher Scientific Inc. provides this document to its customers with a product purchase to use in the product operation. This document is copyright protected and any reproduction of the whole or any part of this document is strictly prohibited, except with the written authorization of Thermo Fisher Scientific Inc.

The contents of this document are subject to change without notice. All technical information in this document is for reference purposes only. System configurations and specifications in this document supersede all previous information received by the purchaser.

Thermo Fisher Scientific Inc. makes no representations that this document is complete, accurate or error-free and assumes no responsibility and will not be liable for any errors, omissions, damage or loss that might result from any use of this document, even if the information in the document is followed properly.

This document is not part of any sales contract between Thermo Fisher Scientific Inc. and a purchaser. This document shall in no way govern or modify any Terms and Conditions of Sale, which Terms and Conditions of Sale shall govern all conflicting information between the two documents.

Release history: 50119962-4 printed in October 2009.

For Research Use Only. Not for use in diagnostic procedures.

Centre of Emergency Preparedness and Response
Health Protection Agency
Porton Down
Salisbury
Wiltshire SP4 0JG
United Kingdom



Certificate of Containment Testing

Containment Testing of Thermo Scientific rotor 75003606

Report No. 59-08 H

Report prepared for: Thermo Fisher
Issue Date: 15th January 2009

Test Summary

A Thermo Scientific 75003606 contained rotor (Max speed 6,300 rpm) was supplied by Thermo Fisher and containment tested at 6,300 rpm using the method described in Annex AA of EN 61010-2-020. The rotor was shown to contain a spill when tested in triplicate.

Report Written By

A handwritten signature in blue ink, appearing to be "M. G. P. A.", written over a horizontal dashed line.

Report Authorised By

A handwritten signature in blue ink, written over a horizontal dashed line. To the right of the signature, the date "(28/1/09)" is written in blue ink.

Table of Contents

	Preface	iii
	Scope of Supply	iii
	Precautions	iii
Chapter 1	Rotor Specifications	1-1
	Heraeus	1-2
	230V 50Hz/60Hz ventilated	1-2
	230V 50Hz/60Hz refrigerated	1-2
	120V 60Hz ventilated	1-3
	120V 60Hz refrigerated	1-3
	Sorvall	1-4
	230V 50Hz/60Hz ventilated	1-4
	230V 50Hz/60Hz refrigerated	1-4
	120V 60Hz ventilated	1-5
	120V 60Hz refrigerated	1-5
	100V 50/60Hz ventilated	1-6
	100V 50/60Hz refrigerated	1-6
	Thermo Scientific	1-7
	230V 50Hz/60Hz ventilated	1-7
	230V 50Hz/60Hz refrigerated	1-7
Chapter 2	Accessories	2-1
	Rotor Loading	2-2
Chapter 3	AutoLock™	3-1
	Rotor Installation	3-2
	Removing the Rotor	3-3
Chapter 4	Rotor Loading	4-1
	Before a Run	4-2
	Proper Loading	4-2
	Improper Loading	4-2
	Maximum Loading	4-3
	Cycle Counter	4-3
Chapter 5	Aerosol-tight Applications	5-1
	Basic Principles	5-2
	Placing O-ring	5-2
	Fill Level	5-2
	Checking the Aerosol-Tightness	5-2

Chapter 6	Maintenance and Care	6-1
	Cleaning intervalls	6-2
	Cleaning	6-2
	Disinfection	6-3
	Decontamination	6-4
	Autoclaving	6-5
	Service of Thermo Fisher Scientific	6-5
	RCF-values	A-1
	Chemical Compatibility Chart	B-1
	Contact Information	C-1

Preface

Before starting to use the rotor, read through these Operating Instructions carefully and follow the instructions.

The information contained in these Operating Instructions is the property of Thermo Fisher Scientific; it is forbidden to copy or pass on this information without explicit approval.

Failure to follow the instructions and safety information in this instruction manual will result in the expiration of the seller's warranty.

Scope of Supply

Article Number		Quantity	Check
75003606	HIGHPlate™	1	<input type="checkbox"/>
76003500	Rubber seal grease	1	<input type="checkbox"/>
75003786	Bolt grease	1	<input type="checkbox"/>
50119962	Instruction Manual	1	<input type="checkbox"/>

If any parts are missing, please contact the nearest Thermo Fisher Scientific representative.

Precautions

In order to ensure safe operation of the HIGHPlate™, the following general safety regulations must be followed:

- Do not remove the magnet at the rotor bottom
- Do not use rotors which show any signs of corrosion and/or cracks.
- Use only with rotors which have been loaded properly.
- Never overload the rotor.

Preface

- Use only accessories which have been approved by Thermo Fisher Scientific. Exceptions to this rule are commercially available glass or plastic centrifuge tubes, provided they have been approved for the speed or the RCF value of the rotor.
- Please observe the safety instructions.

Please pay particular attention to the following aspects:

- Rotor installation: Check that the rotor is locked properly into place before operating the centrifuge.
- Always balance the samples.

Maximum sample density at maximum speed: $1.2 \frac{g}{cm^3}$



This symbol refers to general hazards.

CAUTION means that material damage could occur.

WARNING means that injuries or material damage or contamination could occur.



This symbol refers to biological hazards.

Observe the information contained in the instruction manual to keep yourself and your environment safe.

Rotor Specifications

Contents

- “Heraeus” on page 1-2
- “Sorvall” on page 1-4
- “Thermo Scientific” on page 1-7

Heraeus

Tabelle 1-1. 230V 50Hz/60Hz ventilated

Centrifuge	Heraeus Multifuge X3	Heraeus Multifuge X3 F
Catalog #	75004500	75004530
Weight empty [kg]	8	8
Max. cycle number	50000	50000
Maximum permissible load [g]	2x500	2x500
Maximum speed n_{max} [rpm]	6300	6300
Maximum RCF value at n_{max}	6168	6168
Max. / min. radius [cm]	13.9 / 5.8	13.9 / 5.8
Accel. / braking time [s]	60 / 65	60 / 65
Sample heating at n_{max} [° C] referred to ambient temperature of 23 °C, running time 120 minutes	1	1
Aerosol-tight*	yes	yes
Permissible temperature range autoclavable (cycle number) °C	121	121

*Tested by HPA, Porton-down, UK

Tabelle 1-2. 230V 50Hz/60Hz refrigerated

Centrifuge	Heraeus Multifuge X3R	Heraeus Multifuge X3 FR
Catalog #	75004515	75004536
Weight empty [kg]	8	8
Max. cycle number	50000	50000
Maximum permissible load [g]	2x500	2x500
Maximum speed n_{max} [rpm]	6300	6300
Maximum RCF value at n_{max}	6168	6168
Max. / min. radius [cm]	13.9 / 5.8	13.9 / 5.8
Accel. / braking time [s]	60 / 65	60 / 65
Aerosol-tight*	yes	yes
Permissible temperature range autoclavable (cycle number) °C	121	121

*Tested by HPA, Porton-down, UK

Tabelle 1-3. 120V 60Hz ventilated

Centrifuge	Heraeus Multifuge X3	Heraeus Multifuge X3 F
Catalog #	75004501	75004531
Weight empty [kg]	8	8
Max. cycle number	50000	50000
Maximum permissible load [g]	2x500	2x500
Maximum speed n_{max} [rpm]	6300	6300
Maximum RCF value at n_{max}	6168	6168
Max. / min. radius [cm]	13.9 / 5.8	13.9 / 5.8
Accel. / braking time [s]	90 / 65	90 / 65
Sample heating at n_{max} [°C] referred to ambient temperature of 23 °C, running time 120 minutes	5	5
Aerosol-tight*	yes	yes
Permissible temperature range autoclavable (cycle number) °C	121	121

*tested by HPA, Porton-down, UK

Table 1-4. 120V 60Hz refrigerated

Centrifuge	Heraeus Multifuge X3R	Heraeus Multifuge X3 FR
Catalog #	75004516	75004537
Weight empty [kg]	8	8
Max. cycle number	50000	50000
Maximum permissible load [g]	2x500	2x500
Maximum speed n_{max} [rpm]	6300	6300
Maximum RCF value at n_{max}	6168	6168
Max. / min. radius [cm]	13.9 / 5.8	13.9 / 5.8
Accel. / braking time [s]	90 / 65	90 / 65
Aerosol-tight*	yes	yes
Permissible temperature range autoclavable (cycle number) °C	121	121

*tested by HPA, Porton-down, UK

Sorvall

Tabelle 1-5. 230V 50Hz/60Hz ventilated

Centrifuge	Sorvall Legend XT	Sorvall Legend XF
Catalog #	75004505	75004532
Weight empty [kg]	8	8
Max. cycle number	50000	50000
Maximum permissible load [g]	2x500	2x500
Maximum speed n_{max} [rpm]	6300	6300
Maximum RCF value at n_{max}	6168	6168
Max. / min. radius [cm]	13.9 / 5.8	13.9 / 5.8
Accel. / braking time [s]	60 / 65	60 / 65
Sample heating at n_{max} [°C] referred to ambient temperature of 23 °C, running time 120 minutes	1	1
Aerosol-tight*	yes	yes
Permissible temperature range autoclavable (cycle number) °C	121	121

*tested by HPA, Porton-down, UK

Tabelle 1-6. 230V 50Hz/60Hz refrigerated

Centrifuge	Sorvall Legend XTR	Sorvall Legend XFR
Catalog #	75004520	75004538
Weight empty [kg]	8	8
Max. cycle number	50000	50000
Maximum permissible load [g]	2x500	2x500
Maximum speed n_{max} [rpm]	6300	6300
Maximum RCF value at n_{max}	6168	6168
Max. / min. radius [cm]	13.9 / 5.8	13.9 / 5.8
Accel. / braking time [s]	60 / 65	60 / 65
Aerosol-tight*	yes	yes
Permissible temperature range autoclavable (cycle number) °C	121	121

*tested by HPA, Porton-down, UK

Tabelle 1-7. 120V 60Hz ventilated

Centrifuge	Sorvall Legend XT	Sorvall Legend XF
Catalog #	75004506	75004533
Weight empty [kg]	8	8
Max. cycle number	50000	50000
Maximum permissible load [g]	2x500	2x500
Maximum speed n_{max} [rpm]	6300	6300
Maximum RCF value at n_{max}	6168	6168
Max. / min. radius [cm]	13.9 / 5.8	13.9 / 5.8
Accel. / braking time [s]	90 / 65	90 / 65
Sample heating at n_{max} [°C] referred to ambient temperature of 23 °C, running time 120 minutes	5	5
Aerosol-tight*	yes	yes
Permissible temperature range autoclavable (cycle number) °C	121	121

*tested by HPA, Porton-down, UK

Table 1-8. 120V 60Hz refrigerated

Centrifuge	Sorvall Legend XTR	Sorvall Legend XFR
Catalog #	75004521	75004539
Weight empty [kg]	8	8
Max. cycle number	50000	50000
Maximum permissible load [g]	2x500	2x500
Maximum speed n_{max} [rpm]	6300	6300
Maximum RCF value at n_{max}	6168	6168
Max. / min. radius [cm]	13.9 / 5.8	13.9 / 5.8
Accel. / braking time [s]	90 / 65	90 / 65
Aerosol-tight*	yes	yes
Permissible temperature range autoclavable (cycle number) °C	121	121

*tested by HPA, Porton-down, UK

1 Rotor Specifications

Sorvall

Tabelle 1-9. 100V 50/60Hz ventilated

Centrifuge	Sorvall Legend XT	Sorvall Legend XF
Catalog #	75004507	75004534
Weight empty [kg]	8	8
Max. cycle number	50000	50000
Maximum permissible load [g]	2x500	2x500
Maximum speed n_{\max} [rpm]	6300	6300
Maximum RCF value at n_{\max}	6168	6168
Max. / min. radius [cm]	13.9 / 5.8	13.9 / 5.8
Accel. / braking time [s]	90 / 65	90 / 65
Sample heating at n_{\max} [°C] referred to ambient temperature of 23 °C, running time 120 minutes	5	5
Aerosol-tight*	yes	yes
Permissible temperature range autoclavable (cycle number) °C	121	121

*tested by HPA, Porton-down, UK

Table 1-10. 100V 50/60Hz refrigerated

Centrifuge	Sorvall Legend XTR	Sorvall Legend XFR
Catalog #	75004522	75004540
Weight empty [kg]	8	8
Max. cycle number	50000	50000
Maximum permissible load [g]	2x500	2x500
Maximum speed n_{\max} [rpm]	6300	6300
Maximum RCF value at n_{\max}	6168	6168
Max. / min. radius [cm]	13.9 / 5.8	13.9 / 5.8
Accel. / braking time [s]	90 / 65	90 / 65
Aerosol-tight*	yes	yes
Permissible temperature range autoclavable (cycle number) °C	121	121

*tested by HPA, Porton-down, UK

Thermo Scientific

Tabelle 1-11. 230V 50Hz/60Hz ventilated

Centrifuge	Thermo Scientific SL40 F
Catalog #	75004542
Weight empty [kg]	8
Max. cycle number	50000
Maximum permissible load [g]	2x500
Maximum speed n_{\max} [rpm]	6300
Maximum RCF value at n_{\max}	6168
Max. / min. radius [cm]	13.9 / 5.8
Accel. / braking time [s]	60 / 65
Sample heating at n_{\max} [°C] referred to ambient temperature of 23 °C, running time 120 minutes	1
Aerosol-tight*	yes
Permissible temperature range autoclavable (cycle number) °C	121

*tested by HPA, Porton-down, UK

Tabelle 1-12. 230V 50Hz/60Hz refrigerated

Centrifuge	Thermo Scientific SL40 FR
Catalog #	75004543
Weight empty [kg]	8
Max. cycle number	50000
Maximum permissible load [g]	2x500
Maximum speed n_{\max} [rpm]	6300
Maximum RCF value at n_{\max}	6168
Max. / min. radius [cm]	13.9 / 5.8
Accel. / braking time [s]	60 / 65
Aerosol-tight*	yes
Permissible temperature range autoclavable (cycle number) °C	121

*tested by HPA, Porton-down, UK

Accessories

Content

- “Rotor Loading” on page 2-2

Rotor Loading



CAUTION The HIGHPlate™ must always be used with the lid.

Handeling Micro Plate Carriers

1. Always remove the microplates from the microplate carriers for loading.
2. Make sure you use a rubber bottom placed in the cut outs of the micro plate carrier.
Deepwell plates may be used without the rubber bottom.
3. Make sure the load is balanced.
4. Place the loaded micro plate carriers in th rotor.

AutoLock™

Contents

- “Rotor Installation” on page 3-2
- “Removing the Rotor” on page 3-3

Rotor Installation



CAUTION Unapproved or incorrectly combined accessories can cause serious damage to the centrifuge.

This rotor is equipped with an AutoLock™-system.

This system is used to automatically lock the rotor to the centrifuge spindle. The rotor does not have to be bolted onto the centrifuge spindle.

Proceed as follows:

1. Open the lid of the centrifuge and if necessary remove any dust, foreign objects or residue from the chamber.
AutoLock™ and o-ring must be clean and undamaged.

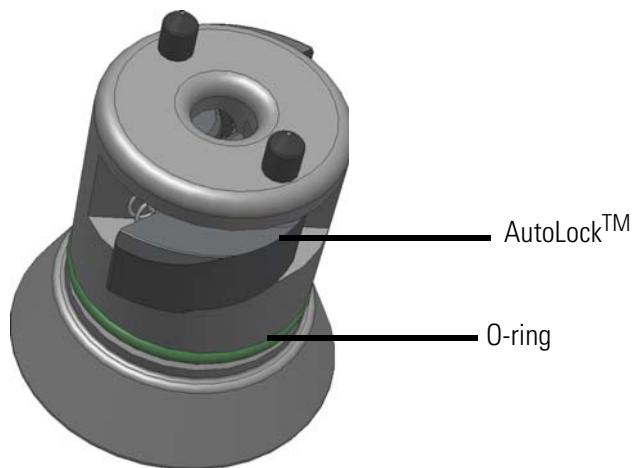

Figure 3-1. AutoLock™

2. Hold the rotor over the centrifuge spindle and let it slide slowly down the centrifuge spindle. The rotor clicks automatically into place.



CAUTION Do not force the rotor onto the centrifuge spindle. If the rotor is very light, then it may be necessary to press it onto the centrifuge spindle with a small amount of pressure.

3. Check if the rotor is properly installed by lifting slightly on the handle. If the rotor can be pulled up, then it must be reclamped to the centrifuge spindle.



WARNING If the rotor cannot be properly locked in place after several attempts, then the AutoLock™ is defective and you are not permitted to operate the rotor. Check for any damage to the rotor, damaged rotors must not be used. Keep the hub area clear of objects.



CAUTION Check that the rotor is properly locked on the centrifuge spindle before each use by pulling it a its handle.



Be sure to check all seals before starting any aerosol-tight applications.

4. Close the centrifuge door.

Removing the Rotor

To remove the rotor, proceed as follows:

1. Open the centrifuge door.
2. Grab the rotor handle with both hands and press against the green AutoLock™ button. At the same time, pull the rotor directly upwards with both hands and remove it from the centrifuge spindle. Make sure not to jam the rotor while doing this.

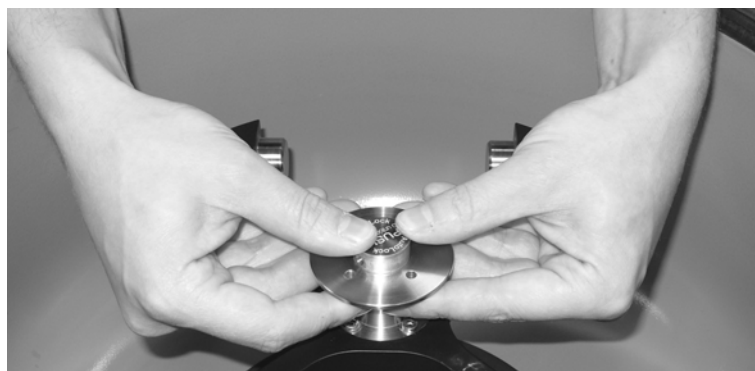

Rotor Loading

Contents

- “Before a Run” on page 4-2
- “Proper Loading” on page 4-2
- “Improper Loading” on page 4-2
- “Maximum Loading” on page 4-3
- “Cycle Counter” on page 4-3

Before a Run

1. Please read and observe the safety instructions contained in these operating instructions and in the instructions for use.
2. Check the rotor and all accessory parts for damages such as cracks, scratches or traces of corrosion.
3. Check the rotor chamber, the motor shaft and the Autolock™.
4. Check the rotor's suitability using the chemical compatibility chart on [page B-1](#).
5. Make sure the tubes do not touch the microplate carrier lid.
6. Check the rotor bolts and apply grease 7500 3786 before using for the first time.
7. Check that each microplate carrier can swing freely by moving it carefully with your hand. Weigh the bucket content (adaptor and tube). Make sure you do not exceed the maximum compartment load.

Proper Loading

To ensure safe operation of the centrifuge, the rotor must be evenly loaded at all times

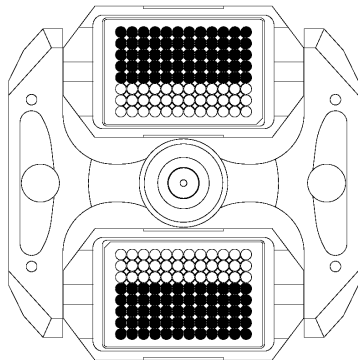

Improper Loading

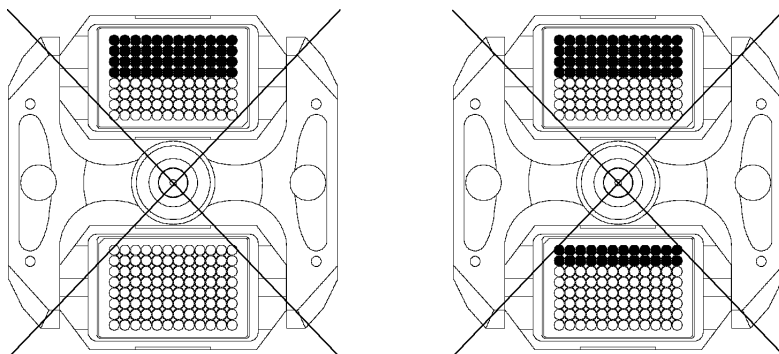

Maximum Loading

The rotor can run at high speeds. The rotor design has sufficient reserve stability even when spinning at top speed.

The safety system of the centrifuge requires that you do not overload the rotor.

There are two options available for centrifuging samples whose weight, including adaptor, exceeds the maximum permissible load:

- Reduce the fill level.
- Reduce the speed.

Use the table or the formula:

Actual Load (g/carrier)	RPM _{max}
770	4000
790	3949
810	3900
830	3853
850	3807
870	3763
890	3721
910	3679
930	3640
950	3601
970	3564
990	3528
1010	3493

$$n_{adm} = n_{max} \sqrt{\frac{\text{Maximum permissible load}}{\text{Effective load}}}$$

n_{adm} = admissible speed

n_{max} = maximum speed

Cycle Counter

The lifetime of rotors and microplate carriers is dependent on the amount of mechanical load. Do not exceed the number of cycles recommended for rotors and microplate carriers.

The maximum number of cycles is given in the rotor table in the rotor specification section.



WARNING Replace the rotor when the specified number of cycles is reached. Due to the mechanical load a rotor can break and thus damage the centrifuge

Service life examples

Usage profile	Maximum service life at 30,000 cycles
frequent use 20 runs / day 220 days / year	7 years

Aerosol-tight Applications

Contents

- “Basic Principles” on page 5-2
- “Fill Level” on page 5-2
- “Checking the Aerosol-Tightness” on page 5-2

Basic Principles



CAUTION When centrifuging hazardous samples, do not open aerosol-tight rotors or buckets unless placed in a safety cabinet. Always bear in mind the maximum permitted fill levels.



Be sure to check all seals before starting any aerosol-tight applications.

- Check that the sample containers are well suited for the desired centrifugation process.

Placing O-ring

The o-ring fulfills its purpose best, when it is neither stressed nor bulked. Meaning the o-ring should be equally placed in the groove of the lid.

Place the o-ring as follows:

1. Place the o-ring above the groove.
2. Push the o-ring on two opposite places into the groove. Make sure the rest of the o-ring is equally distributed.
3. Push the centers of the loose parts into the groove.
4. Push the remaining o-ring into place.

Note If the o-ring seems to be too long or too short, take it off the lid and repeat the process.

Fill Level

The tubes are only to be filled to a level which ensures that the sample is unable to reach the top of the tube during centrifugation. Therefore fill the tube only 2/3 of the rated level.

Checking the Aerosol-Tightness

The aerosol tightness testing of the rotors and buckets depend on the microbiological test process in accordance with the EN 61010-2-020 Appendix AA.

Whether or not a rotor is aerosol-tight depends primarily on proper handling.

Check as needed to make sure your rotor is aerosol-tight.

The careful inspection of the seals and seal surfaces for signs of wear and damage such as cracks, scratches and embrittlement is extremely important.

Aerosol-tight applications are not possible if the lids are open.

Aerosol-tightness requires the correct operation when filling the sample vessels and closing the rotor lid.

Quick Test

As a quick test, it is possible to test the aerosol-tight buckets using the following process:

1. Lubricate all seals lightly.
Always use the special grease 7600 3500 when lubricating the seals.
2. Fill the bucket with approx. 10 ml of carbonated mineral water.
3. Close the bucket as explained in the handling instructions.
4. Shake the bucket vigorously using your hands.
This releases the carbonic acid gas which is bound in the water, resulting in excess pressure. Do not apply pressure to the lid when doing so.

Leaks can be detected by escaping water or the sound of escaping gas.

Replace the seals if you detect any leaks. Then repeat the test.

5. Dry the rotor, rotor cover and the cover seal.



CAUTION Prior to each use, the seals in the bucket are to be inspected in order to assure that they are correctly seated and are not worn or damaged.

Damaged seals are to be replaced immediately.

When loading the rotor, ensure that the rotor lid closes securely.

Damaged or clouded rotor covers are to be replaced immediately!

Maintenance and Care

Contents

- “Cleaning intervals” on page 6-2
- “Cleaning” on page 6-2
- “Disinfection” on page 6-3
- “Decontamination” on page 6-4
- “Autoclaving” on page 6-5
- “Service of Thermo Fisher Scientific” on page 6-5

Cleaning intervals

For the sake of personal, environmental, and material protection, it is your duty to clean and if necessary disinfect the centrifuge on a regular basis.

Maintenance	Recommended interval
Clean rotor chamber	daily or when polluted
Clean rotor	daily or when polluted
Accessories	daily or when polluted
Cabinet	Once per month
Ventilation holes	Every six months



CAUTION Refrain from using any other cleaning or decontamination procedure than those recommended here, if you are not entirely sure that the intended procedure is safe for the equipment.

Use only approved cleansers.

If in doubt, contact Thermo Fisher Scientific.

Cleaning

When cleaning centrifug

- Use warm water with a neutral solvent.
- Never use caustic cleaning agents such as soap suds, phosphoric acid, bleaching solutions or scrubbing powder.
- Rinse the cavities out thoroughly.
- Use a soft brush without metal bristles to remove stubborn residue.
- Afterwards rinse with distilled water.
- Place the rotors on a plastic grate with their cavities pointing down.
- If drying boxes are used, the temperature must never exceed 50 °C, since higher temperatures could damage the material and shorten the lifetime of the parts.
- Use only disinfectants with a pH of 6-8.
- Dry aluminum parts off with a soft cloth.
- After cleaning, treat the entire surface of aluminum parts with corrosion protection oil (7000 9824). Also treat the cavities with oil.
- Store the aluminum parts at room temperature or in a cold-storage room with the cavities pointing down.



CAUTION Before using any cleaning or decontamination methods except those recommended by the manufacturer, users should check with the manufacturer that the proposed method will not damage the equipment.

Clean centrifuge and accessories as follows:

1. Open the centrifuge.
2. Turn off the centrifuge.
3. Pull out the power supply plug.
4. Grasp the rotor with both hands and lift it vertically off the centrifuge spindle.
5. Remove the centrifuge tubes and adaptors.
6. Use a neutral cleaning agent with a pH value between 6 and 8 for cleaning.
7. Dry all of the rotors and accessories after cleaning with a cloth or in a warm air cabinet at a maximum temperature of 50°C.
8. Clean the housing of the centrifuge as needed.
 - After cleaning, treat the entire surface of aluminum parts with corrosion protection oil (7000 9824). Also treat the cavities with oil.
 - Treat the bolt of the swing out rotor with bolt grease (75003786).



CAUTION When cleaning, do not allow liquids, especially organic solvents, to get on the drive shaft, the bearings, the AutoLock™ or the locks. Organic solvents break down the grease in the motor bearing. The drive shaft could freeze up.

After some applications there might be ice in the rotor chamber. Let the ice melt and drain it off. Clean the rotor chamber as described above.

Disinfection

Disinfect the centrifuge immediately whenever infectious material has spilled during centrifugation.



WARNING Infectious material can get into the centrifuge when a tube breaks or as a result of spills. Keep in mind the risk of infection when touching the rotor and take all necessary precautions. In case of contamination, make sure that others are not put at risk. Decontaminate the affected parts immediately. Take other precautions if needed.

Use a sprayer whenever possible so that all surfaces are covered evenly.

The rotor chamber and the rotor should be treated preferably with a neutral disinfectant. A disinfectant spray would be most suitable for this purpose so that the rotor and accessory surfaces are covered evenly.



CAUTION Before using any cleaning or decontamination methods except those recommended by the manufacturer, users should check with the manufacturer that the proposed method will not damage the equipment. Observe the safety precautions and handling instructions for the cleaning agents used.

Contact the Service Department of Thermo Fisher Scientific for questions regarding the use of other disinfectants.

Disinfect the rotor and accessories as follows:

1. Open the centrifuge.
2. Turn off the centrifuge.
3. Pull out the power supply plug.
4. Grasp the rotor with both hands and lift it vertically off the centrifuge spindle.
5. Remove the centrifuge tubes and adaptors and dispose of them or disinfect them.
6. Treat the rotor and accessories according to the instructions for the disinfectant (spray or soak in solution). Adhere strictly to the given application times.
7. Be sure the disinfectant can drain off the rotor.
8. Rinse the rotor and rotor lid thoroughly with water and then rub down.
9. Dispose of the disinfectant according to the applicable guidelines.
10. Dry all of the rotors and accessories after cleaning with a cloth or in a warm air cabinet at a maximum temperature of 50°C.
 - After cleaning, treat the entire surface of aluminum parts with corrosion protection oil (7000 9824). Also treat the cavities with oil.
 - Tread the bolt of the swing out rotor with bolt grease (75003786).

Decontamination

Decantaminate the centrifuge immediately whenever radioactive material has spilled during centrifugation.



WARNING Radioactive material can get into the centrifuge when a tube breaks or as a result of spills. Keep in mind the risk of infection when touching the rotor and take all necessary precautions.
In case of contamination, make sure that others are not put at risk.
Decontaminate the affected parts immediately.
Take other precautions if need be.



CAUTION Before using any cleaning or decontamination methods except those recommended by the manufacturer, users should check with the manufacturer that the proposed method will not damage the equipment.

For general radioactive decontamination use a solution of equal parts of 70% ethanol, 10% SDS and water.

Disinfect the rotor and accessories as follows:

1. Open the centrifuge.
2. Turn off the centrifuge.
3. Pull out the power supply plug.

4. Grasp the rotor with both hands and lift it vertically off the centrifuge spindle.
5. Remove the centrifuge tubes and adaptors and dispose of them or disinfect them.
6. Rinse the rotor first with ethanol and then with de-ionized water.
 - Adhere strictly to the given application times.
7. Be sure the decontamination solution can drain off the rotor.
8. Rinse the rotor and accessories thoroughly with water.
9. Dispose of the decontamination solution according to the applicable guidelines.
10. Dry all of the rotors and accessories after cleaning with a cloth or in a warm air cabinet at a maximum temperature of 50°C.
 - After cleaning, treat the entire surface of aluminum parts with corrosion protection oil (7000 9824). Also treat the cavities with oil.
 - Treat the bolt of the swing out rotor with bolt grease (75003786).

Autoclaving

1. Before autoclaving clean rotor and accessories as described above.
2. Place the rotor
3. on a flat surface.
 - Rotors and adapter can be autoclaved at 121 °C.
 - The maximum permissible autoclave cycle is 20 minutes at 121 °C.

Clean the rotor before autoclaving and rinse it with distilled water. Remove all accessories (tubes, adapters) from the rotor. Place the rotor on a flat surface.

Note No chemical additives are permitted in the steam.



CAUTION Never exceed the permitted temperature and duration when autoclaving. If the rotor shows signs of corrosion or wear, it must be replaced.

Service of Thermo Fisher Scientific

Thermo Fisher Scientific recommends having the centrifuge and accessories serviced once a year by an authorized service technician. The service technicians check the following:

- the electrical equipment
- the suitability of the set-up site
- the lid lock and the safety system
- the rotor
- the fixation of the rotor and the drive shaft

Thermo Fisher Scientific offers inspection and service contracts for this work.

RCF-values

Speed (rpm)	R _{min}	R _{max}	RCF R _{min}	RCF R _{max}
300	5.8	13.9	6	14
400	5.8	13.9	10	25
500	5.8	13.9	16	39
600	5.8	13.9	23	56
700	5.8	13.9	32	76
800	5.8	13.9	42	99
900	5.8	13.9	53	126
1000	5.8	13.9	65	155
1100	5.8	13.9	78	188
1200	5.8	13.9	93	224
1300	5.8	13.9	110	263
1400	5.8	13.9	127	305
1500	5.8	13.9	146	350
1600	5.8	13.9	166	398
1700	5.8	13.9	187	449
1800	5.8	13.9	210	504
1900	5.8	13.9	234	561
2000	5.8	13.9	259	622
2100	5.8	13.9	286	685
2200	5.8	13.9	314	752
2300	5.8	13.9	343	822
2400	5.8	13.9	374	895
2500	5.8	13.9	405	971
2600	5.8	13.9	438	1051
2700	5.8	13.9	473	1133
2800	5.8	13.9	508	1218
2900	5.8	13.9	545	1307
3000	5.8	13.9	584	1399
3100	5.8	13.9	623	1493

A RCF-values

Speed (rpm)	R _{min}	R _{max}	RCF R _{min}	RCF R _{max}
3200	5.8	13.9	664	1591
3300	5.8	13.9	706	1692
3400	5.8	13.9	750	1796
3500	5.8	13.9	794	1904
3600	5.8	13.9	840	2014
3700	5.8	13.9	888	2127
3800	5.8	13.9	936	2244
3900	5.8	13.9	986	2364
4000	5.8	13.9	1038	2486
4100	5.8	13.9	1090	2612
4200	5.8	13.9	1144	2741
4300	5.8	13.9	1199	2873
4400	5.8	13.9	1255	3009
4500	5.8	13.9	1313	3147
4600	5.8	13.9	1372	3288
4700	5.8	13.9	1432	3433
4800	5.8	13.9	1494	3580
4900	5.8	13.9	1557	3731
5000	5.8	13.9	1621	3885
5100	5.8	13.9	1687	4042
5200	5.8	13.9	1753	4202
5300	5.8	13.9	1821	4365
5400	5.8	13.9	1891	4532
5500	5.8	13.9	1962	4701
5600	5.8	13.9	2034	4873
5700	5.8	13.9	2107	5049
5800	5.8	13.9	2181	5228
5900	5.8	13.9	2257	5410
6000	5.8	13.9	2334	5594
6100	5.8	13.9	2413	5783
6200	5.8	13.9	2493	5974
6300	5.8	13.9	2574	6168

Chemical Compatibility Chart

CHEMICAL	MATERIAL	ALUMINUM	ANODIC COATING for ALUMINUM	BUNA N	CELLULOSE ACETATE BUTYRATE	POLYURETHANE ROTOR PAINT	COMPOSITE Carbon Fiber/Epoxy	DELIRIN®	ETHYLENE PROPYLENE	GLASS	NEOPRENE	NORYL®	NYLON	PET®, POLYCLEAR®, CLEARCRIMP®, CCLEARCRIMP®	POLYALLOMER	POLYCARBONATE	POLYTER, GLASS THERMOSET	POLYETHERIMIDE	POLYETHYLENE	POLYPROPYLENE	POLYSULFONE	POLYVINYL CHLORIDE	RULONA®, TEFLON®	SILICONE RUBBER	STAINLESS STEEL	TITANIUM	TYGON®	VITON®
2-mercaptoethanol		S	S	U	-	S	M	S	-	S	U	S	S	U	S	S	-	S	S	S	S	U	S	S	S	S	S	S
Acetaldehyde		S	-	U	U	-	-	-	M	-	U	-	-	-	M	U	U	U	M	M	-	M	S	U	-	S	-	U
Acetone		M	S	U	U	S	U	M	S	S	U	U	S	U	S	U	U	U	S	S	U	U	S	M	M	S	U	U
Acetonitrile		S	S	U	-	S	M	S	-	S	S	U	S	U	M	U	U	-	S	M	U	U	S	S	S	S	U	U
Alconox®		U	U	S	-	S	S	S	-	S	S	S	S	S	S	M	S	S	S	S	S	S	S	S	S	S	S	U
Allyl Alcohol		-	-	-	U	-	-	S	-	-	-	-	S	-	S	S	M	S	S	S	-	M	S	-	-	S	-	-
Aluminum Chloride		U	U	S	S	S	S	U	S	S	S	S	M	S	S	S	S	-	S	S	S	S	S	M	U	U	S	S
Formic Acid (100%)		-	S	M	U	-	-	U	-	-	-	-	U	-	S	M	U	U	S	S	-	U	S	-	U	S	-	U
Ammonium Acetate		S	S	U	-	S	S	S	-	S	S	S	S	S	S	S	U	-	S	S	S	S	S	S	S	S	S	S
Ammonium Carbonate		M	S	U	S	S	S	S	S	S	S	S	S	S	S	U	U	-	S	S	S	S	S	S	M	S	S	S
Ammonium Hydroxide (10%)		U	U	S	U	S	S	M	S	S	S	S	S	-	S	U	M	S	S	S	S	S	S	S	S	S	M	S
Ammonium Hydroxide (28%)		U	U	S	U	S	U	M	S	S	S	S	S	U	S	U	M	S	S	S	S	S	S	S	S	S	M	S
Ammonium Hydroxide (conc.)		U	U	U	U	S	U	M	S	-	S	-	S	U	S	U	U	S	S	S	-	M	S	S	S	S	-	U
Ammonium Phosphate		U	-	S	-	S	S	S	S	S	S	S	S	-	S	S	M	-	S	S	S	S	S	S	M	S	S	S
Ammonium Sulfate		U	M	S	-	S	S	U	S	S	S	S	S	S	S	S	S	-	S	S	S	S	S	S	U	S	S	U
Amyl Alcohol		S	-	M	U	-	-	S	S	-	M	-	S	-	M	S	S	S	S	M	-	-	-	U	-	S	-	M
Aniline		S	S	U	U	S	U	S	M	S	U	U	U	U	U	U	U	-	S	M	U	U	S	S	S	S	U	S
Sodium Hydroxide (<1%)		U	-	M	S	S	S	-	-	S	M	S	S	-	S	M	M	S	S	S	S	S	S	M	S	S	-	U
Sodium Hydroxide (10%)		U	-	M	U	-	-	U	-	M	M	S	S	U	S	U	U	S	S	S	S	S	S	M	S	S	-	U
Barium Salts		M	U	S	-	S	S	S	S	S	S	S	S	S	S	S	M	-	S	S	S	S	S	S	M	S	S	S
Benzene		S	S	U	U	S	U	M	U	S	U	U	S	U	U	U	M	U	M	U	U	U	S	U	U	S	U	S
Benzyl Alcohol		S	-	U	U	-	-	M	M	-	M	-	S	U	U	U	U	U	U	U	-	M	S	M	-	S	-	S
Boric Acid		U	S	S	M	S	S	U	S	S	S	S	S	S	S	S	S	U	S	S	S	S	S	S	S	S	S	S

B Chemical Compatibility Chart

CHEMICAL	MATERIAL	MATERIAL																									
		ALUMINUM	ANODIC COATING for ALUMINUM	BUNA N	CELLULOSE ACETATE BUTYRATE	POLYURETHANE ROTOR PAINT	COMPOSITE Carbon Fiber/Epoxy	DELRIN®	ETHYLENE PROPYLENE	GLASS	NEOPRENE	NORLYL®	NYLON	PET*, POLYCLEAR®, CLEARCRIMP®, CCLEARCRIMP®	POLYALLUMER	POLYCARBONATE	POLTER, GLASS THERMOSET	POLYETHERIMIDE	POLYTRHYLENE	POLYPROPYLENE	POLYSULFONE	POLYVINYL CHLORIDE	RULON A®, TEFLON®	SILICONE RUBBER	STAINLESS STEEL	TITANIUM	TYGON®
Cesium Acetate	M	-	S	-	S	S	S	-	S	S	S	S	-	S	S	-	-	S	S	S	S	S	S	M	S	S	S
Cesium Bromide	M	S	S	-	S	S	S	-	S	S	S	S	S	S	S	-	-	S	S	S	S	S	S	M	S	S	S
Cesium Chloride	M	S	S	U	S	S	S	-	S	S	S	S	S	S	S	-	-	S	S	S	S	S	S	M	S	S	S
Cesium Formate	M	S	S	-	S	S	S	-	S	S	S	S	S	S	S	-	-	S	S	S	S	S	S	M	S	S	S
Cesium Iodide	M	S	S	-	S	S	S	-	S	S	S	S	S	S	S	-	-	S	S	S	S	S	S	M	S	S	S
Cesium Sulfate	M	S	S	-	S	S	S	-	S	S	S	S	S	S	S	-	-	S	S	S	S	S	S	M	S	S	S
Chloroform	U	U	U	U	S	S	M	U	S	U	U	M	U	M	U	U	U	M	M	U	U	S	U	U	U	M	S
Chromic Acid (10%)	U	-	U	U	S	U	U	-	S	S	S	U	S	S	M	U	M	S	S	U	M	S	M	U	S	S	S
Chromic Acid (50%)	U	-	U	U	-	U	U	-	-	-	S	U	U	S	M	U	M	S	S	U	M	S	-	U	M	-	S
Cresol Mixture	S	S	U	-	-	-	S	-	S	U	U	U	U	U	U	-	-	U	U	-	U	S	S	S	S	U	S
Cyclohexane	S	S	S	-	S	S	S	U	S	U	S	S	U	U	U	M	S	M	U	M	M	S	U	M	M	U	S
Deoxycholate	S	S	S	-	S	S	S	-	S	S	S	S	S	S	S	-	-	S	S	S	S	S	S	S	S	S	S
Distilled Water	S	S	S	S	S	S	S	S	S	S	S	S	S	S	S	S	S	S	S	S	S	S	S	S	S	S	S
Dextran	M	S	S	S	S	S	S	-	S	S	S	S	S	S	S	S	S	S	S	S	S	S	S	M	S	S	S
Diethyl Ether	S	S	U	U	S	S	S	U	S	U	U	S	U	U	U	U	U	U	U	U	U	S	S	S	S	M	U
Diethyl Ketone	S	-	U	U	-	-	M	-	S	U	-	S	-	M	U	U	U	M	M	-	U	S	-	-	S	U	U
Diethylpyrocarbonate	S	S	U	-	S	S	S	-	S	S	U	S	U	S	U	-	-	S	S	S	M	S	S	S	S	S	S
Dimethylsulfoxide	S	S	U	U	S	S	S	-	S	U	S	S	U	S	U	U	-	S	S	U	U	S	S	S	U	U	U
Dioxane	M	S	U	U	S	S	M	M	S	U	U	S	U	M	U	U	-	M	M	M	U	S	S	S	S	U	U
Ferric Chloride	U	U	S	-	-	-	M	S	-	M	-	S	-	S	-	-	-	S	S	-	-	-	M	U	S	-	S
Acetic Acid (Glacial)	S	S	U	U	S	S	U	M	S	U	S	U	U	U	U	U	M	S	U	M	U	S	U	U	S	-	U
Acetic Acid (5%)	S	S	M	S	S	S	M	S	S	S	S	S	M	S	S	S	S	S	S	S	M	S	S	M	S	S	M
Acetic Acid (60%)	S	S	U	U	S	S	U	-	S	M	S	U	U	M	U	S	M	S	M	S	M	S	M	U	S	M	U
Ethyl Acetate	M	M	U	U	S	S	M	M	S	S	U	S	U	M	U	U	-	S	S	U	U	S	M	M	S	U	U
Ethyl Alcohol (50%)	S	S	S	S	S	S	M	S	S	S	S	S	U	S	U	S	S	S	S	S	S	S	S	M	S	M	U
Ethyl Alcohol (95%)	S	S	S	U	S	S	M	S	S	S	S	S	U	S	U	-	S	S	S	M	S	S	S	U	S	M	U
Ethylene Dichloride	S	-	U	U	-	-	S	M	-	U	U	S	U	U	U	U	U	U	U	-	U	S	U	-	S	-	S
Ethylene Glycol	S	S	S	S	S	S	S	S	S	S	S	S	-	S	U	S	S	S	S	S	S	S	S	M	S	M	S
Ethylene Oxide Vapor	S	-	U	-	-	U	-	-	S	U	-	S	-	S	M	-	-	S	S	S	U	S	U	S	S	S	U
Ficoll-Hypaque®	M	S	S	-	S	S	S	-	S	S	S	S	-	S	S	-	S	S	S	S	S	S	M	S	S	S	S

CHEMICAL	MATERIAL																										
	ALUMINUM	ANODIC COATING for ALUMINUM	BUNA N	CELLULOSE ACETATE BUTYRATE	POLYURETHANE ROTOR PAINT	COMPOSITE Carbon Fiber/Epoxy	DELRIN®	ETHYLENE PROPYLENE	GLASS	NEOPRENE	NORYL®	NYLON	PET®, POLYCLEAR® ,CLEARCRIMP®,CCLEARCRIMP®	POLYALLUMER	POLYCARBONATE	POLTER, GLASS THERMOSET	POLYETHERIMIDE	POLYRTHYLENE	POLYPROPYLENE	POLYSULFONE	POLYVINYL CHLORIDE	RULON A®, TEFLON®	SILICONE RUBBER	STAINLESS STEEL	TITANIUM	TYGON®	VITON®
Hydrofluoric Acid (10%)	U	U	U	M	-	-	U	-	-	U	U	S	-	S	M	U	S	S	S	S	M	S	U	U	U	-	-
Hydrofluoric Acid (50%)	U	U	U	U	-	-	U	-	-	U	U	U	U	S	U	U	U	S	S	M	M	S	U	U	U	-	M
Hydrochloric Acid (conc.)	U	U	U	U	-	U	U	M	-	U	M	U	U	M	U	U	U	-	S	-	U	S	U	U	U	-	-
Formaldehyde (40%)	M	M	M	S	S	S	S	M	S	S	S	S	M	S	S	S	U	S	S	M	S	S	S	M	S	M	U
Glutaraldehyde	S	S	S	S	-	-	S	-	S	S	S	S	S	S	S	-	-	S	S	S	-	-	S	S	S	-	-
Glycerol	M	S	S	-	S	S	S	S	S	S	S	S	S	S	S	S	-	S	S	S	S	S	S	S	S	S	S
Guanidine Hydrochloride	U	U	S	-	S	S	S	-	S	S	S	S	S	S	S	-	-	S	S	S	S	S	S	U	S	S	S
Haemo-Sol®	S	S	S	-	-	-	S	-	S	S	S	S	S	S	S	-	-	S	S	S	S	S	S	S	S	S	S
Hexane	S	S	S	-	S	S	S	-	S	S	U	S	U	M	U	S	S	U	S	S	M	S	U	S	S	U	S
Isobutyl Alcohol	-	-	M	U	-	-	S	S	-	U	-	S	U	S	S	M	S	S	S	-	S	S	S	-	S	-	S
Isopropyl Alcohol	M	M	M	U	S	S	S	S	S	U	S	S	U	S	U	M	S	S	S	S	S	S	S	M	M	M	S
Iodoacetic Acid	S	S	M	-	S	S	S	-	S	M	S	S	M	S	S	-	M	S	S	S	S	S	M	S	S	M	M
Potassium Bromide	U	S	S	-	S	S	S	-	S	S	S	S	S	S	S	S	S	S	S	-	S	S	S	M	S	S	S
Potassium Carbonate	M	U	S	S	S	S	S	-	S	S	S	S	S	U	S	S	S	S	S	S	S	S	S	S	S	S	S
Potassium Chloride	U	S	S	-	S	S	S	S	S	S	S	S	S	S	-	S	S	S	S	S	S	S	U	S	S	S	S
Potassium Hydroxide (5%)	U	U	S	S	S	S	M	-	S	S	S	S	-	S	U	S	S	S	S	S	S	S	M	U	M	S	U
Potassium Hydroxide (conc.)	U	U	M	U	-	-	M	-	M	S	S	-	U	M	U	U	U	S	M	-	M	U	-	U	U	-	U
Potassium Permanganate	S	S	S	-	S	S	S	-	S	S	S	U	S	S	S	M	-	S	M	S	U	S	S	M	S	U	S
Calcium Chloride	M	U	S	S	S	S	S	S	S	S	S	S	S	S	M	S	-	S	S	S	S	S	S	M	S	S	S
Calcium Hypochlorite	M	-	U	-	S	M	M	S	-	M	-	S	-	S	M	S	-	S	S	S	M	S	M	U	S	-	S
Kerosene	S	S	S	-	S	S	S	U	S	M	U	S	U	M	M	S	-	M	M	M	S	S	U	S	S	U	S
Sodium Chloride (10%)	S	-	S	S	S	S	S	S	-	-	-	S	S	S	S	S	-	S	S	S	S	-	S	S	M	-	S
Sodium Chloride (sat'd)	U	-	S	U	S	S	S	-	-	-	-	S	S	S	S	-	S	S	-	S	-	S	S	M	-	S	
Carbon Tetrachloride	U	U	M	S	S	U	M	U	S	U	U	S	U	M	U	S	S	M	M	S	M	M	M	M	U	S	S
Aqua Regia	U	-	U	U	-	-	U	-	-	-	-	-	U	U	U	U	U	U	U	-	-	-	-	-	S	-	M
Solution 555 (20%)	S	S	S	-	-	-	S	-	S	S	S	S	S	S	-	-	S	S	S	-	S	S	S	S	S	S	S
Magnesium Chloride	M	S	S	-	S	S	S	S	S	S	S	S	S	S	S	S	S	S	S	S	S	S	S	M	S	S	S
Mercaptoacetic Acid	U	S	U	-	S	M	S	-	S	M	S	U	U	U	U	-	S	U	U	S	M	S	U	S	S	S	S
Methyl Alcohol	S	S	S	U	S	S	M	S	S	S	S	U	S	U	M	S	S	S	S	S	S	S	M	S	M	U	U
Methylene Chloride	U	U	U	U	M	S	S	U	S	U	U	S	U	U	U	U	U	M	U	U	U	S	M	U	S	U	U

B Chemical Compatibility Chart

CHEMICAL	MATERIAL																											
	ALUMINUM	ANODIC COATING for ALUMINUM	BUNA N	CELLULOSE ACETATE BUTYRATE	POLYURETHANE ROTOR PAINT	COMPOSITE Carbon Fiber/Epoxy	DELRIN®	ETHYLENE PROPYLENE	GLASS	NEOPRENE	NORYL®	NYLON	PET®, POLYCLEAR®, CLEARCRIMP®, CCLEARCRIMP®	POLYALLUMER	POLYCARBONATE	POLYTER, GLASS THERMOSET	POLYETHERIMIDE	POLYTRHYLENE	POLYPROPYLENE	POLYSULFONE	POLYVINYL CHLORIDE	RULON A®, TEFLON®	SILICONE RUBBER	STAINLESS STEEL	TITANIUM	TYGON®	VITON®	
Methyl Ethyl Ketone	S	S	U	U	S	S	M	S	S	U	U	S	U	S	U	U	U	S	S	U	U	S	S	S	S	U	U	
Metrizamide®	M	S	S	-	S	S	S	-	S	S	S	S	-	S	S	-	-	S	S	S	S	S	S	S	M	S	S	S
Lactic Acid (100%)	-	-	S	-	-	-	-	-	-	M	S	U	-	S	S	S	M	S	S	-	M	S	M	S	S	-	S	
Lactic Acid (20%)	-	-	S	S	-	-	-	-	-	M	S	M	-	S	S	S	S	S	S	S	M	S	M	S	S	-	S	
N-Butyl Alcohol	S	-	S	U	-	-	S	-	-	S	M	-	U	S	M	S	S	S	S	M	M	S	M	-	S	-	S	
N-Butyl Phthalate	S	S	U	-	S	S	S	-	S	U	U	S	U	U	U	M	-	U	U	S	U	S	M	M	S	U	S	
N, N-Dimethylformamide	S	S	S	U	S	M	S	-	S	S	U	S	U	S	U	U	-	S	S	U	U	S	M	S	S	S	U	
Sodium Borate	M	S	S	S	S	S	S	S	S	S	S	U	S	S	S	S	-	S	S	S	S	S	S	M	S	S	S	
Sodium Bromide	U	S	S	-	S	S	S	-	S	S	S	S	S	S	S	S	-	S	S	S	S	S	S	M	S	S	S	
Sodium Carbonate (2%)	M	U	S	S	S	S	S	S	S	S	S	S	S	S	U	S	S	S	S	S	S	S	S	S	S	S	S	
Sodium Dodecyl Sulfate	S	S	S	-	S	S	S	-	S	S	S	S	S	S	S	-	S	S	S	S	S	S	S	S	S	S	S	
Sodium Hypochlorite (5%)	U	U	M	S	S	M	U	S	S	M	S	S	S	M	S	S	S	S	M	S	S	S	M	U	S	M	S	
Sodium Iodide	M	S	S	-	S	S	S	-	S	S	S	S	S	S	S	-	-	S	S	S	S	S	S	M	S	S	S	
Sodium Nitrate	S	S	S	-	S	S	S	S	S	S	S	S	S	S	S	S	-	S	S	S	S	S	U	S	S	S	S	
Sodium Sulfate	U	S	S	-	S	S	S	S	S	S	S	S	S	S	S	S	S	S	S	S	S	S	S	M	S	S	S	
Sodium Sulfide	S	-	S	S	-	-	-	S	-	-	-	S	S	S	U	U	-	-	S	-	-	-	S	S	M	-	S	
Sodium Sulfite	S	S	S	-	S	S	S	S	M	S	S	S	S	S	S	M	-	S	S	S	S	S	S	S	S	S	S	
Nickel Salts	U	S	S	S	S	S	-	S	S	S	-	-	S	S	S	S	-	S	S	S	S	S	M	S	S	S	S	
Oils (Petroleum)	S	S	S	-	-	-	S	U	S	S	S	S	U	U	M	S	M	U	U	S	S	U	S	S	S	S		
Oils (Other)	S	-	S	-	-	-	S	M	S	S	S	S	U	S	S	S	S	U	S	S	S	S	-	S	S	M	S	
Oleic Acid	S	-	U	S	S	S	U	U	S	U	S	S	M	S	S	S	S	S	S	S	S	S	M	U	S	M	M	
Oxalic Acid	U	U	M	S	S	S	U	S	S	S	S	U	S	U	S	S	S	S	S	S	S	S	U	M	S	S	S	
Perchloric Acid (10%)	U	-	U	-	S	U	U	-	S	M	M	-	-	M	U	M	S	M	M	-	M	S	U	-	S	-	S	
Perchloric Acid (70%)	U	U	U	-	-	U	U	-	S	U	M	U	U	M	U	U	U	M	M	U	M	S	U	U	S	U	S	
Phenol (5%)	U	S	U	-	S	M	M	-	S	U	M	U	U	S	U	M	S	M	S	U	U	S	U	M	M	M	S	
Phenol (50%)	U	S	U	-	S	U	M	-	S	U	M	U	U	U	U	U	S	U	M	U	U	S	U	U	U	M	S	
Phosphoric Acid (10%)	U	U	M	S	S	S	U	S	S	S	S	U	-	S	S	S	S	S	S	S	S	S	U	M	U	S	S	
Phosphoric Acid (conc.)	U	U	M	M	-	-	U	S	-	M	S	U	U	M	M	S	S	S	M	S	M	S	U	M	U	-	S	
Physiologic Media (Serum, Urine)	M	S	S	S	-	-	S	-	S	S	S	S	S	S	S	S	S	S	S	S	S	S	S	S	S	S	S	
Picric Acid	S	S	U	-	S	M	S	S	S	M	S	U	S	S	S	U	S	S	S	S	U	S	U	M	S	M	S	

CHEMICAL	MATERIAL																										
	ALUMINUM	ANODIC COATING for ALUMINUM	BUNA N	CELLULOSE ACETATE BUTYRATE	POLYURETHANE ROTOR PAINT	COMPOSITE Carbon Fiber/Epoxy	DELRIN®	ETHYLENE PROPYLENE	GLASS	NEOPRENE	NORYL®	NYLON	PET®, POLYCLEAR® ,CLEARCRIMP®,CCLEARCRIMP®	POLYALLUMER	POLYCARBONATE	POLTER, GLASS THERMOSET	POLYETHERIMIDE	POLYTRHYLENE	POLYPROPYLENE	POLYSULFONE	POLYVINYL CHLORIDE	RULON A®, TEFLON®	SILICONE RUBBER	STAINLESS STEEL	TITANIUM	TYGON®	VITON®
Pyridine (50%)	U	S	U	U	S	U	U	-	U	S	S	U	U	M	U	U	-	U	S	M	U	S	S	U	U	U	U
Rubidium Bromide	M	S	S	-	S	S	S	-	S	S	S	S	S	S	S	-	-	S	S	S	S	S	S	M	S	S	S
Rubidium Chloride	M	S	S	-	S	S	S	-	S	S	S	S	S	S	S	-	-	S	S	S	S	S	S	M	S	S	S
Sucrose	M	S	S	-	S	S	S	S	S	S	S	S	S	S	S	S	S	S	S	S	S	S	S	S	S	S	S
Sucrose, Alkaline	M	S	S	-	S	S	S	-	S	S	S	S	S	S	U	S	S	S	S	S	S	S	S	M	S	S	S
Sulfosalicylic Acid	U	U	S	S	S	S	S	-	S	S	S	U	S	S	S	-	S	S	S	-	S	S	S	U	S	S	S
Nitric Acid (10%)	U	S	U	S	S	U	U	-	S	U	S	U	-	S	S	S	S	S	S	S	S	S	M	S	S	S	S
Nitric Acid (50%)	U	S	U	M	S	U	U	-	S	U	S	U	U	M	M	U	M	M	M	S	S	S	U	S	S	M	S
Nitric Acid (95%)	U	-	U	U	-	U	U	-	-	U	U	U	U	M	U	U	U	U	M	U	U	S	U	S	S	-	S
Hydrochloric Acid (10%)	U	U	M	S	S	S	U	-	S	S	S	U	U	S	U	S	S	S	S	S	S	S	S	U	M	S	S
Hydrochloric Acid (50%)	U	U	U	U	S	U	U	-	S	M	S	U	U	M	U	U	S	S	S	S	M	S	M	U	U	M	M
Sulfuric Acid (10%)	M	U	U	S	S	U	U	-	S	S	M	U	S	S	S	S	S	S	S	S	S	S	U	U	U	S	S
Sulfuric Acid (50%)	M	U	U	U	S	U	U	-	S	S	M	U	U	S	U	U	M	S	S	S	S	S	U	U	U	M	S
Sulfuric Acid (conc.)	M	U	U	U	-	U	U	M	-	-	M	U	U	S	U	U	U	M	S	U	M	S	U	U	U	-	S
Stearic Acid	S	-	S	-	-	-	S	M	S	S	S	S	-	S	S	S	S	S	S	S	S	S	M	M	S	S	S
Tetrahydrofuran	S	S	U	U	S	U	U	M	S	U	U	S	U	U	U	-	M	U	U	U	U	S	U	S	S	U	U
Toluene	S	S	U	U	S	S	M	U	S	U	U	S	U	U	U	S	U	M	U	U	U	S	U	S	U	U	M
Trichloroacetic Acid	U	U	U	-	S	S	U	M	S	U	S	U	U	S	M	-	M	S	S	U	U	S	U	U	U	M	U
Trichloroethane	S	-	U	-	-	-	M	U	-	U	-	S	U	U	U	U	U	U	U	U	U	S	U	-	S	-	S
Trichloroethylene	-	-	U	U	-	-	-	U	-	U	-	S	U	U	U	U	U	U	U	U	U	S	U	-	U	-	S
Trisodium Phosphate	-	-	-	S	-	-	M	-	-	-	-	-	-	S	-	-	S	S	S	-	-	S	-	-	S	-	S
Tris Buffer (neutral pH)	U	S	S	S	S	S	S	-	S	S	S	S	S	S	S	S	S	S	S	S	S	S	S	S	S	S	S
Triton X-100®	S	S	S	-	S	S	S	-	S	S	S	S	S	S	S	S	S	S	S	S	S	S	S	S	S	S	S
Urea	S	-	U	S	S	S	S	-	-	-	-	S	S	S	M	S	S	S	S	-	S	S	S	M	S	-	S
Hydrogen Peroxide (10%)	U	U	M	S	S	U	U	-	S	S	S	U	S	S	S	M	U	S	S	S	S	S	S	M	S	U	S
Hydrogen Peroxide (3%)	S	M	S	S	S	-	S	-	S	S	S	S	S	S	S	S	M	S	S	S	S	S	S	S	S	S	S
Xylene	S	S	U	S	S	S	M	U	S	U	U	U	U	U	U	M	U	M	U	U	U	S	U	M	S	U	S
Zinc Chloride	U	U	S	S	S	U	S	S	S	S	S	S	S	S	S	S	S	S	S	S	S	S	S	U	S	S	S
Zinc Sulfate	U	S	S	-	S	S	S	S	S	S	S	S	S	S	S	S	S	S	S	S	S	S	S	S	S	S	S
Citric Acid (10%)	M	S	S	M	S	S	M	S	S	S	S	S	S	S	S	S	M	S	S	S	S	S	S	S	S	S	S

B Chemical Compatibility Chart

*Polyethyleneterephthalate

Key

S Satisfactory

M = Moderate attack, may be satisfactory for use in centrifuge depending on length of exposure, speed involved, etc.; suggest testing under actual conditions of use.

U Unsatisfactory, not recommended.

-- Performance unknown; suggest testing, using sample to avoid loss of valuable material.

Chemical resistance data is included only as a guide to product use. Because no organized chemical resistance data exists for materials under the stress of centrifugation, when in doubt we recommend pretesting sample lots.

Contact Information

United States	866-9-THERMO
	+1 866 984 3766

Canada	+1 866 984 3766
--------	-----------------

Austria	+43 1 801 400
---------	---------------

Belgium	+32 2 482 30 30
---------	-----------------

Germany	08001 536 376
	+49 6184 90 6940

France	+33 2 2803 2180
	+33 2 2803 2000

Italy	+39 02 02 95059 341
-------	---------------------

Netherlands	+31 76 571 4440
-------------	-----------------

Nordic / Baltic Countries	+35 89 329 100
---------------------------	----------------

Russia	+7 (812) 703 42 15
--------	--------------------

Contact Information

Spain +34 932 23 09 18

Portugal +34 932 23 09 18

Switzerland +41 44 454 12 12

UK / Ireland +44 870 609 9203

China +86 21 6865 4588

+86 10 8419 3588

India +91 22 6716 2200

Japan +81 45 453 9220

Other Asian Countries +852 2885 4613

Latin America +1 866 984 3766

Other Countries +49 6184 90 6940

+33 2 2803 2180

Index

A	
Accessories	2-1
Aerosol-tight Applications	5-1
Autoclaving	6-5
AutoLock™	3-1
B	
Basic Principles	5-2
Before a Run	4-2
C	
Care	6-1
Checking the Aerosol-Tightness	5-2
Chemical Compatibility Chart	B-1
Cleaning	6-2
Cleaning agents	6-3
Cycle Counter	4-3
D	
Decontamination	6-4
Disinfection	6-3
F	
Fill Level	5-2
H	
Heraeus	1-2
I	
Improper Loading	4-2
M	
Maintenance	6-1
Maximum Loading	4-3
P	
Placing O-ring	5-2
Precautions	iii
Preface	iii
Proper Loading	4-2
Q	
Quick Test	5-3
R	
Removing the Rotor	3-3
Rotor Installation	3-2
Rotor Loading	4-1
S	
Scope of Supply	iii
Service Technician	6-5
Sorvall	1-4
T	
Thermo Scientific	1-7

